

MACHINED TYPE NEEDLE ROLLER BEARINGS

- Machined Type Caged Needle Roller Bearings
- Machined Type Guide Needle Roller Bearings



Structure and Features

IKO Machined Type Needle Roller Bearings are bearings with a low sectional height and large load ratings. The outer ring has high rigidity and can easily be used even for light alloy housings. These bearings are available in metric series and inch series, both of which have the caged type and the full complement type. It is therefore possible to select a suitable bearing for use under various conditions such as heavy loads and high-speed or low-speed rotations. In addition, there are bearings with and without an inner ring. As the type without inner ring uses a shaft as the raceway surface, a compact design is possible.

Structures of Machined Type Needle Roller Bearings

RNA49 · TAF

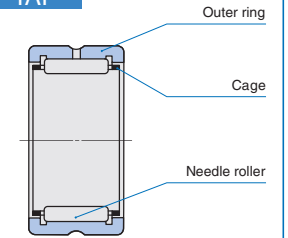

NA49 · TAFI

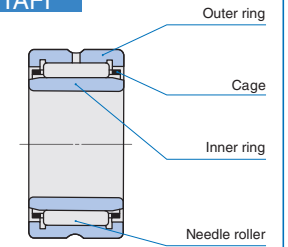

RNA49··UU · TAF··UU

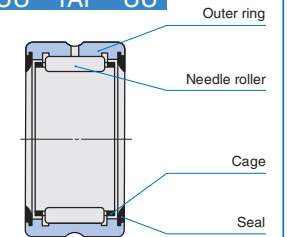

GTR

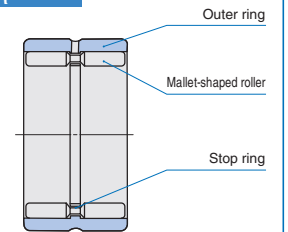

D

NA
TAFI
TRI
BRI

Types

Machined Type Needle Roller Bearings are available in various types shown in Table 1.

Table 1.1 Type of bearing (Standard type)

Series	Type	Caged Needle Roller Bearings		Guide Needle Roller Bearings	
		Without inner ring	With inner ring	Without inner ring	With inner ring
Metric series	Dimension series 49	RNA 49	NA 49	GTR	GTRI
	Dimension series 69	RNA 69	NA 69		
	Dimension series 48	RNA 48	NA 48		
	For heavy duty	TR	TRI		
	For light duty	TAF	TAFI		
Inch series		BR	BRI	GBR	GBRI

Table 1.2 Type of bearing (With seal)

Series	Type	Caged Needle Roller Bearings		Guide Needle Roller Bearings	
		Without inner ring	With inner ring	Without inner ring	With inner ring
Metric series	Dimension series 49	Two side seals RNA 49··UU	NA 49··UU	—	—
		One side seal RNA 49··U	NA 49··U		
Metric series	Dimension series 69	Two side seals RNA 69··UU	NA 69··UU	—	—
		One side seal RNA 69··U	NA 69··U		
Inch series	Two side seals	BR··UU	BRI··UU	GBR··UU	GBRI··UU
	One side seal	BR··U	BRI··U	GBR··U	GBRI··U

Caged Needle Roller Bearings

This type of bearing combines a collared outer ring with the IKO's unique lightweight rigid cage and needle rollers. During operation, needle rollers are guided precisely by the cage, and an ideal load distribution is obtained.

The metric series consists of the NA48 and NA49 series of ISO Standard, NA69 and TAFI series which are based on the international dimension series, and the heavy duty TRI series which is widely used in Japan. The TAFI series has a sectional height as low as that of the shell type and is used for light loads.

The inch series or BRI series is based on the specifications of ANSI Standard of USA.

Caged Needle Roller Bearings without Inner Ring

As shown in the section "Design of shaft and housing" on page A44, any desired radial clearance can be selected by assembling this type of bearing with a shaft which is heat-treated and finished by grinding. These bearings are free from the effects on dimensional accuracy caused by assembling an inner ring,

so that the rotational accuracy is improved. Also, the shaft rigidity can be improved as the shaft diameter can be increased by an amount corresponding to the inner ring thickness.

Caged Needle Roller Bearings with Inner Ring

This type of bearing is used when the shaft cannot be heat-treated and finished by grinding. The outer and inner rings are separable and a small relief clearance is provided on both sides of the inner ring raceway to facilitate bearing mounting. In the TRI and BRI series, the width of the inner ring is larger than that of the outer ring.

Due to heat expansion during operation or mounting errors, the inner or outer ring may be shifted axially and the whole length of the rollers may not be in contact with the raceway. Therefore, attention should be paid to the allowable axial shift *S* as shown in the table of dimensions.

Needle Roller Bearings with Seal

These bearings are sealed types of the NA49, NA69 and BRI series bearings, in which a seal is installed on one side (type with one seal) or both sides (type with two seals) of the bearing. The seal is made of special synthetic rubber and effectively prevents dust penetration and grease leakage.

Guide Needle Roller Bearings

These bearings are full complement type bearings and use mallet-shaped rollers which are guided accurately by the guide rail located at the center of the outer ring raceway and the guide groove of the mallet-shaped roller. This minimizes skewing (tilting of the roller from its rotating axis), which is normally a weak point of full complement bearings, and improves the rotational accuracy. This type of bearing is especially suitable for heavy loads, shock loads and oscillating motions.

The bearings are available in metric and inch series. Bearings with and without inner rings are available in both series. In bearings with an inner ring, the width of the inner ring is larger than that of the outer ring.

The GBRI series of the inch series includes types with a seal or seals which are incorporated on one or both sides.

Identification Number

The identification number of Machined Type Needle Roller Bearings consists of a model code, dimensions, any supplemental codes and a classification symbol. Examples are shown below.

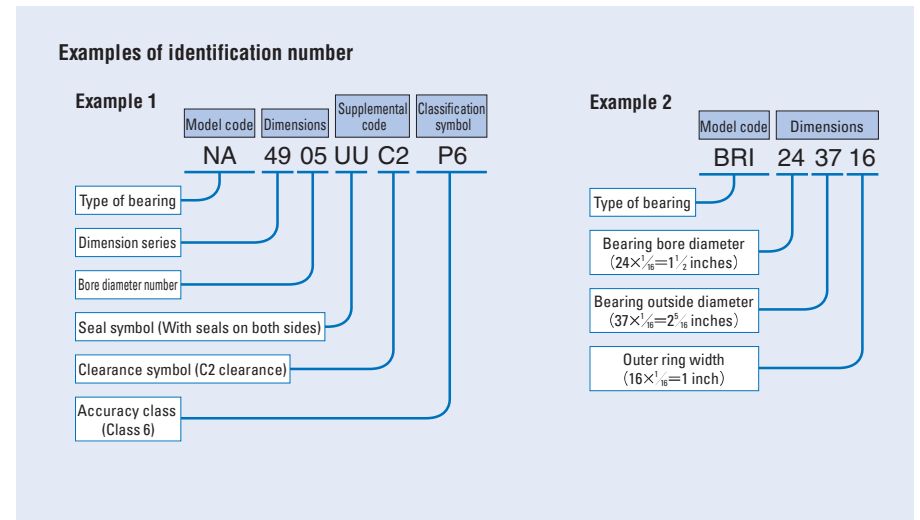

Accuracy

Machined Type Needle Roller Bearings are manufactured based on JIS (See page A31.). The tolerances for the smallest single roller set bore diameter of bearings without inner ring are based on Table 14 on page A33. For BR and BRI series, the accuracy is based on Table 2 and the tolerances for the smallest single roller set bore diameter are based on Table 3.

Table 2 Accuracy of inner and outer rings of inch series BR and BRII⁽¹⁾

unit: μm

<i>d</i> or <i>D</i> Nominal bearing bore dia. or outside dia. mm		Δ_{dmp} Single plane mean bore diameter deviation		Δ_{Dmp} Single plane mean outside diameter deviation		Δ_{Bs} (Δ_{Cs}) Deviation of a single inner (or outer) ring width		K_{ia} Radial runout of assembled bearing inner ring	K_{ea} Radial runout of assembled bearing outer ring
Over	Incl.	High	Low	High	Low	High	Low	Max.	Max.
—	19.050	0	−10	—	—	0	−130	10	—
19.050	30.162	0	−13	0	−13	0	−130	13	15
30.162	50.800	0	−13	0	−13	0	−130	15	20
50.800	82.550	0	−15	0	−15	0	−130	20	25
82.550	120.650	0	−20	0	−20	0	−130	25	35
120.650	184.150	—	—	0	−25	0	−130	30	45

Remark *d* for Δ_{dmp} , Δ_{Bs} , Δ_{Cs} and K_{ia} , and *D* for Δ_{Dmp} and K_{ea}
Note(1) For GBR, GBRI, refer to Metric series tables on pages A31 and A32.

Table 3 Tolerances for smallest single roller set bore diameter $F_{ws\ min}$ of inch series BR⁽¹⁾ unit: μ m

F_w Nominal roller set bore diameter mm		$\Delta F_{ws\ min}$ Deviation of smallest single roller set bore diameter	
Over	Incl.	High	Low
—	18.034	+ 43	+ 20
18.034	30.226	+ 46	+ 23
30.226	41.910	+ 48	+ 25
41.910	50.038	+ 51	+ 25
50.038	70.104	+ 53	+ 28
70.104	80.010	+ 58	+ 28
80.010	102.108	+ 61	+ 31

Note⁽¹⁾ For GBR, refer to Metric series tables on page A33.

Clearance

Radial internal clearances of Machined Type Needle Roller Bearings are made to the CN clearance shown in Table 18 on page A37. Radial internal clearances of BRI series are based on Table 4.

Table 4 Radial internal clearance of inch series BRI⁽¹⁾ unit: μ m

F_w Nominal roller set bore diameter mm		Radial internal clearance	
Over	Incl.	Min.	Max.
—	18.034	33	66
18.034	25.908	41	76
25.908	30.226	46	82
30.226	35.052	48	86
35.052	41.910	50	89
41.910	50.038	50	92
50.038	70.104	56	99
70.104	80.010	56	104
80.010	100.076	63	117
100.076	102.108	68	127

Note⁽¹⁾ For GBRI, refer to Metric series tables on page A37.

Table 5 Bearings with prepacked grease

○ : With prepacked grease × : Without prepacked grease

Bearing type			Standard type	With seals on both sides	With a seal on one side
Caged Needle Roller Bearings	Metric series	RNA, NA	×	○	×
		TR, TRI	×	—	—
		TAF, TAFI, TAF/SG	×	—	—
	Inch series	BR, BRI	×	○	×
Guide Needle Roller Bearings	Metric series	GTR, GTRI	×	—	—
	Inch series	GBR, GBRI	×	○	×

Fit

The recommended fits for Machined Type Needle Roller Bearings are shown in Tables 22 to 24 on pages A41 and A42.

Lubrication

Bearings with prepacked grease are shown in Table 5. ALVANIA GREASE S2 (SHOWA SHELL SEKIYU K.K.) is prepacked as the lubricating grease. In the case of bearings without prepacked grease, perform proper lubrication. Operating them without lubrication will increase the wear of the rolling contact surfaces and shorten their lives.

Oil Hole

Table 6.1 shows the number of oil holes of the outer ring and Table 6.2 shows the number of oil holes of the inner ring.

When an outer ring with an oil hole is especially required for the type without an oil hole, add "—OH" before the clearance symbol in the identification number. When an outer ring with an oil hole and an oil groove is required for the type without an oil hole, attach "—OG" before the clearance symbol.

Example: TAFI 203216 — OH C2 P6

When an outer ring with multiple oil holes or an inner ring with an oil hole(s) is required, please consult

IKO.

Table 6.1 Number of oil holes of the outer ring

Bearing type			Number of oil holes of the outer ring			
		Nominal roller set bore diameter F_w mm	Standard type	With seals on both sides	With a seal on one side	
Caged Needle Roller Bearings	Metric series	RNA, NA	1	1	1	
		TR, TRI	1	—	—	
		TAF, TAFI	0	—	—	
	Inch series	BR, BRI	$F_w \leq 26$	1	—	—
			$26 < F_w$	1	—	—
				$F_w \leq 69.850$	1	1
Guide Needle Roller Bearings	Metric series	GTR, GTRI	1	—	—	
	Inch series	GBR, GBRI	1	1	1	

Remark The type with an oil hole(s) is provided with an oil groove.

Table 6.2 Number of oil holes of the inner ring

Bearing type			Number of oil holes of the inner ring			
		Nominal bearing bore diameter d mm	Standard type	With seals on both sides	With a seal on one side	
Caged Needle Roller Bearings	Metric series	NA	0	0	0	
		TRI	0	0	0	
		TAFI	0	—	—	
	Inch series	BRI	$d \leq 76.200$	1	1	1
			$76.200 < d$	2	1	1
Guide Needle Roller Bearings	Metric series	GTRI	0	—	—	
	Inch series	GBRI	0	0	0	

Remark The type with an oil hole(s) is provided with an oil groove.

Matched Set Bearings

When using two or more Machined Type Needle Roller Bearings adjacent to each other on the same shaft, it is necessary to obtain an even load distribution. On request, a set of bearings is available, in which bearings are matched to obtain an even load distribution.

Mounting

Mounting dimensions for Machined Type Needle Roller Bearings are shown in the table of dimensions.

MACHINED TYPE NEEDLE ROLLER BEARINGS

Without Inner Ring



Shaft dia. 5 – 15mm

Shaft dia. mm	Identification number						Mass (Ref.) g
	RNA 49	RNA 69	RNA 48	TAF	TR	GTR	
5	—	—	—	TAF 51010	—	—	3.4
	—	—	—	TAF 51012	—	—	4.2
	RNA 493	—	—	—	—	—	4.6
6	RNA 494	—	—	—	—	—	5.3
	—	—	—	TAF 61212	—	—	6.4
7	RNA 495	—	—	—	—	—	5.9
	—	—	—	TAF 71410	—	—	6.9
	—	—	—	TAF 71412	—	—	8.3
8	RNA 496	—	—	—	—	—	7.4
	—	—	—	TAF 81512	—	—	9.1
	—	—	—	TAF 81516	—	—	12.9
9	—	—	—	TAF 91612	—	—	9.8
	—	—	—	TAF 91616	—	—	13.2
	RNA 497	—	—	—	—	—	9.3
10	—	—	—	TAF 101712	—	—	10.7
	—	—	—	TAF 101716	—	—	14.3
	RNA 498	—	—	—	—	—	12.6
12	—	—	—	TAF 121912	—	—	12.2
	—	—	—	TAF 121916	—	—	16.3
	RNA 499	—	—	—	—	—	13.6
14	RNA 4900	—	—	—	—	—	16.5
	—	—	—	TAF 142216	—	—	21
	—	—	—	TAF 142220	—	—	26.5
15	—	—	—	TAF 152316	—	—	22.5
	—	—	—	TAF 152320	—	—	28

Notes⁽¹⁾ Minimum allowable value of chamfer dimension r

⁽²⁾ Allowable rotational speed applies to oil lubrication. For grease lubrication, a maximum of 60% of this value is allowable.

Remarks1. TAF series with a roller set bore diameter F_w of 26 mm or less have no oil hole. In others, the outer ring has an oil groove and an oil hole.

2. No grease is prepacked. Perform proper lubrication.

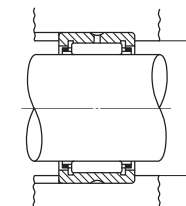
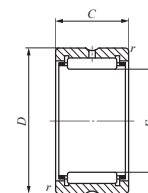

RNA49 TAF
RNA69 ($F_w \leq 35$)

Boundary dimensions mm				Standard mounting dimension D_a Max. mm	Basic dynamic load rating C N	Basic static load rating C_0 N	Allowable rotational speed ⁽²⁾ rpm
F_w	D	C	r_s min ⁽¹⁾				
5	10	10	0.2	8.4	2 420	1 950	80 000
5	10	12	0.2	8.4	3 080	2 660	80 000
5	11	10	0.15	9.8	2 420	1 950	80 000
6	12	10	0.15	10.8	2 700	2 320	70 000
6	12	12	0.2	10.4	3 440	3 170	70 000
7	13	10	0.15	11.8	2 960	2 690	60 000
7	14	10	0.2	12.4	3 600	2 960	60 000
7	14	12	0.2	12.4	4 610	4 050	60 000
8	15	10	0.15	13.8	3 960	3 420	50 000
8	15	12	0.2	13.4	5 060	4 690	50 000
8	15	16	0.2	13.4	7 080	7 220	50 000
9	16	12	0.2	14.4	5 490	5 330	45 000
9	16	16	0.2	14.4	7 680	8 210	45 000
9	17	10	0.15	15.8	4 530	3 650	45 000
10	17	12	0.2	15.4	5 880	5 970	40 000
10	17	16	0.2	15.4	8 230	9 190	40 000
10	19	11	0.2	17.4	6 180	5 030	40 000
12	19	12	0.3	17	6 610	7 260	35 000
12	19	16	0.3	17	9 250	11 200	35 000
12	20	11	0.3	18	6 600	6 310	35 000
14	22	13	0.3	20	9 230	10 100	30 000
14	22	16	0.3	20	11 700	13 700	30 000
14	22	20	0.3	20	14 800	18 600	30 000
15	23	16	0.3	21	12 300	14 900	30 000
15	23	20	0.3	21	15 600	20 200	30 000

D
NA
TAFI
TRI
BRI

MACHINED TYPE NEEDLE ROLLER BEARINGS

Without Inner Ring

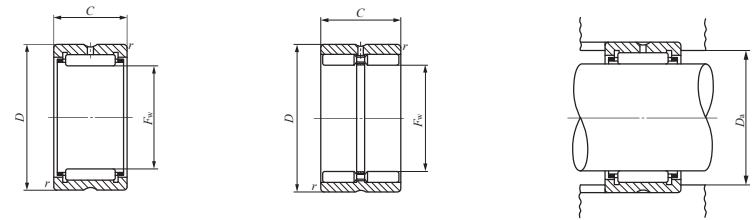

RNA49 TAF TR
RNA69 ($F_w \leq 35$)

GTR

Shaft dia. 16 – 22mm

Shaft dia. mm	Identification number						Mass (Ref.) g
	RNA 49	RNA 69	RNA 48	TAF	TR	GTR	
16	RNA 4901	—	—	—	—	—	18.1
	—	—	—	TAF 162416	—	—	23
	—	—	—	TAF 162420	—	—	29
	—	RNA 6901	—	—	—	—	30
17	—	—	—	TAF 172516	—	—	24.5
	—	—	—	TAF 172520	—	—	30.5
18	RNA 49/14	—	—	—	—	—	19.9
	—	—	—	TAF 182616	—	—	25.5
	—	—	—	TAF 182620	—	—	32
19	—	—	—	TAF 192716	—	—	27
	—	—	—	TAF 192720	—	—	34
20	RNA 4902	—	—	—	—	—	21.5
	—	—	—	TAF 202816	—	—	27.5
	—	—	—	TAF 202820	—	—	35.5
	—	RNA 6902	—	—	—	—	37
	—	—	—	—	TR 203320	—	59.5
	—	—	—	—	—	GTR 203320	69
21	—	—	—	TAF 212916	—	—	29
	—	—	—	TAF 212920	—	—	36
22	RNA 4903	—	—	—	—	—	23.5
	—	—	—	TAF 223016	—	—	30
	—	—	—	TAF 223020	—	—	37.5
	—	RNA 6903	—	—	—	—	40.5
	—	—	—	—	TR 223425	—	73.5
—	—	—	—	—	GTR 223425	87	

Notes⁽¹⁾ Minimum allowable value of chamfer dimension r

⁽²⁾ Allowable rotational speed applies to oil lubrication. For grease lubrication, a maximum of 60% of this value is allowable.

Remarks1. TAF series with a roller set bore diameter F_w of 26 mm or less have no oil hole. In others, the outer ring has an oil groove and an oil hole.

2. No grease is prepacked. Perform proper lubrication.

Boundary dimensions mm				Standard mounting dimension D_a Max. mm	Basic dynamic load rating C N	Basic static load rating C_0 N	Allowable rotational speed ⁽²⁾ rpm
F_w	D	C	$r_{s \min}^{(1)}$				
16	24	13	0.3	22	9 660	11 100	25 000
16	24	16	0.3	22	12 300	15 100	25 000
16	24	20	0.3	22	15 500	20 400	25 000
16	24	22	0.3	22	17 100	23 000	25 000
17	25	16	0.3	23	12 900	16 300	25 000
17	25	20	0.3	23	16 300	22 000	25 000
18	26	13	0.3	24	10 600	12 800	20 000
18	26	16	0.3	24	13 400	17 500	20 000
18	26	20	0.3	24	17 000	23 600	20 000
19	27	16	0.3	25	14 000	18 700	20 000
19	27	20	0.3	25	17 700	25 300	20 000
20	28	13	0.3	26	10 900	13 800	20 000
20	28	16	0.3	26	13 900	18 800	20 000
20	28	20	0.3	26	17 600	25 400	20 000
20	28	23	0.3	26	19 300	28 800	20 000
20	33	20	0.3	31	24 300	26 500	20 000
20	33	20	0.3	31	29 200	37 200	7 500
21	29	16	0.3	27	14 400	20 000	19 000
21	29	20	0.3	27	18 200	27 100	19 000
22	30	13	0.3	28	11 700	15 600	18 000
22	30	16	0.3	28	14 900	21 200	18 000
22	30	20	0.3	28	18 900	28 700	18 000
22	30	23	0.3	28	20 800	32 500	18 000
22	34	25	0.3	32	29 100	36 800	18 000
22	34	25	0.3	32	37 900	57 800	7 000

D

NA
TAFI
TRI
BRI

MACHINED TYPE NEEDLE ROLLER BEARINGS

Without Inner Ring

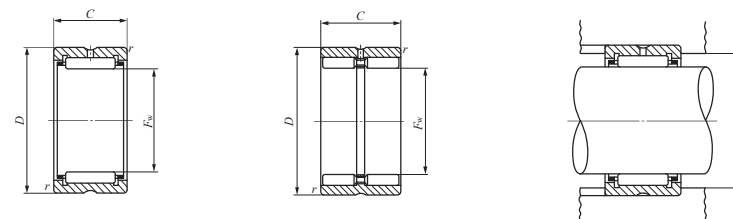

RNA49 TAF TR
RNA69 ($F_w \leq 35$)

GTR

Shaft dia. 24 – 30mm

Shaft dia. mm	Identification number						Mass (Ref.) g
	RNA 49	RNA 69	RNA 48	TAF	TR	GTR	
24	—	—	—	TAF 243216	—	—	32
	—	—	—	TAF 243220	—	—	40.5
25	RNA 4904	RNA 6904	—	TAF 253316	—	—	33.5
			—	TAF 253320	—	—	42
			—	—	—	—	55.5
			—	—	—	—	95.5
	—	—	—	—	TR 253820	—	71
	—	—	—	—	TR 253825	—	89
	—	—	—	—	—	GTR 253820	81.5
	—	—	—	—	—	GTR 253825	104
26	—	—	—	TAF 263416	—	—	34.5
	—	—	—	TAF 263420	—	—	43.5
28	RNA 49/22	—	—	TAF 283720	—	—	51.5
			—	TAF 283730	—	—	83.5
	RNA 69/22	—	—	—	—	—	56.5
		—	—	—	—	—	97.5
29	—	—	—	TAF 293820	—	—	57
	—	—	—	TAF 293830	—	—	85
30	RNA 4905	RNA 6905	—	TAF 304020	—	—	64.5
			—	TAF 304030	—	—	97.5
			—	—	—	—	64
			—	—	—	—	111
	—	—	—	—	TR 304425	—	115
	—	—	—	—	—	GTR 304425	133
	—	—	—	—	—	—	—
	—	—	—	—	—	—	—

Notes⁽¹⁾ Minimum allowable value of chamfer dimension r

⁽²⁾ Allowable rotational speed applies to oil lubrication. For grease lubrication, a maximum of 60% of this value is allowable.

Remarks1. TAF series with a roller set bore diameter F_w of 26 mm or less have no oil hole. In others, the outer ring has an oil groove and an oil hole.

2. No grease is prepacked. Perform proper lubrication.

F_w	Boundary dimensions mm			Standard mounting dimension D_a Max. mm	Basic dynamic load rating C N	Basic static load rating C_0 N	Allowable rotational speed ⁽²⁾ rpm
	D	C	$r_{s \min}^{(1)}$				
24	32	16	0.3	30	15 300	22 500	17 000
24	32	20	0.3	30	19 400	30 500	17 000
25	33	16	0.3	31	15 800	23 700	16 000
25	33	20	0.3	31	20 000	32 100	16 000
25	37	17	0.3	35	21 000	25 000	16 000
25	37	30	0.3	35	35 400	48 900	16 000
25	38	20	0.3	36	28 900	35 000	16 000
25	38	25	0.3	36	34 800	44 400	16 000
25	38	20	0.3	36	33 300	46 500	6 000
25	38	25	0.3	36	42 400	63 700	6 000
26	34	16	0.3	32	16 300	24 900	15 000
26	34	20	0.3	32	20 600	33 800	15 000
28	37	20	0.3	35	21 700	37 100	14 000
28	37	30	0.3	35	31 100	58 900	14 000
28	39	17	0.3	37	21 400	28 900	14 000
28	39	30	0.3	37	36 300	56 900	14 000
29	38	20	0.3	36	21 600	37 200	14 000
29	38	30	0.3	36	30 900	59 100	14 000
30	40	20	0.3	38	25 100	40 100	13 000
30	40	30	0.3	38	36 000	63 900	13 000
30	42	17	0.3	40	23 700	30 700	13 000
30	42	30	0.3	40	42 100	64 300	13 000
30	44	25	0.3	42	37 900	52 100	13 000
30	44	25	0.3	42	47 000	76 500	5 000

D

NA
TAFI
TRI
BRI

MACHINED TYPE NEEDLE ROLLER BEARINGS

Without Inner Ring

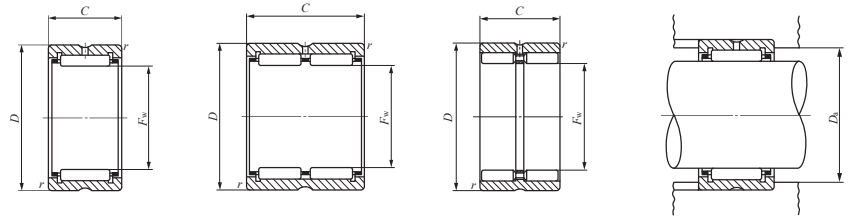

RNA49 TAF TR
RNA69 ($F_w \leq 35$)

RNA69

GTR

Shaft dia. 32 – 40mm

Shaft dia. mm	Identification number						Mass (Ref.) g	
	RNA 49	RNA 69	RNA 48	TAF	TR	GTR		
32	—	—	—	TAF 324220	—	—	68	
	RNA 49/28	—	—	TAF 324230	—	—	102	
		—	RNA 69/28	—	—	—	76.5	
	—	—		—	—	—	133	
	—	—	—	—	—	GTR 324530	152	
35	—	—	—	TAF 354520	—	—	73.5	
	RNA 4906	—	—	TAF 354530	—	—	112	
		—	RNA 6906	—	—	—	72.5	
	—	—		—	—	—	125	
	—	—	—	—	TR 354830	—	139	
	—	—	—	—	—	GTR 354830	163	
37	—	—	—	TAF 374720	—	—	77.5	
	—	—	—	TAF 374730	—	—	117	
38	—	—	—	TAF 384820	—	—	79	
	—	—	—	TAF 384830	—	—	119	
	—	—	—	—	TR 385230	—	168	
	—	—	—	—	—	GTR 385230	195	
40	—	—	—	TAF 405020	—	—	83	
	RNA 49/32	—	—	TAF 405030	—	—	125	
		—	RNA 69/32	—	—	—	96	
	—	—		—	—	—	172	
		—	—	—	—	TR 405520	—	129
		—	—	—	—	—	GTR 405520	144

Notes⁽¹⁾ Minimum allowable value of chamfer dimension r
⁽²⁾ Allowable rotational speed applies to oil lubrication. For grease lubrication, a maximum of 60% of this value is allowable.
 Remarks¹ The outer ring has an oil groove and an oil hole.
 2. No grease is prepacked. Perform proper lubrication.

Boundary dimensions mm				Standard mounting dimension D_a Max. mm	Basic dynamic load rating C N	Basic static load rating C_0 N	Allowable rotational speed ⁽²⁾ rpm
F_w	D	C	$r_{s \min}^{(1)}$				
32	42	20	0.3	40	25 700	42 200	12 000
32	42	30	0.3	40	36 800	67 200	12 000
32	45	17	0.3	43	24 500	32 700	12 000
32	45	30	0.3	43	41 800	64 800	12 000
32	45	30	0.3	43	58 000	101 000	4 500
35	45	20	0.3	43	26 900	46 200	11 000
35	45	30	0.3	43	38 600	73 600	11 000
35	47	17	0.3	45	25 200	34 700	11 000
35	47	30	0.3	45	43 000	69 000	11 000
35	48	30	0.3	46	47 400	72 300	11 000
35	48	30	0.3	46	61 100	110 000	4 500
37	47	20	0.3	45	28 200	50 100	11 000
37	47	30	0.3	45	40 500	79 800	11 000
38	48	20	0.3	46	28 100	50 200	11 000
38	48	30	0.3	46	40 300	80 000	11 000
38	52	30	0.6	48	50 800	81 100	11 000
38	52	30	0.6	48	64 200	121 000	4 000
40	50	20	0.3	48	29 400	54 100	10 000
40	50	30	0.3	48	42 300	86 200	10 000
40	52	20	0.6	48	31 200	47 800	10 000
40	52	36	0.6	48	53 500	95 700	10 000
40	55	20	0.6	51	37 400	55 700	10 000
40	55	20	0.6	51	44 300	73 600	3 500

D
 NA
 TAFI
 TRI
 BRI

MACHINED TYPE NEEDLE ROLLER BEARINGS

Without Inner Ring

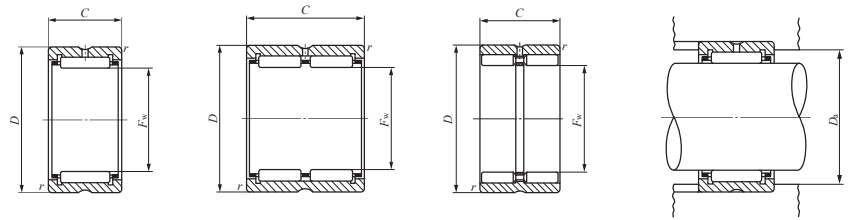

RNA49 TAF TR

RNA69

GTR

Shaft dia. 42 – 50mm

Shaft dia. mm	Identification number						Mass (Ref.) g
	RNA 49	RNA 69	RNA 48	TAF	TR	GTR	
42	—	—	—	TAF 425220	—	—	86.5
	RNA 4907	—	—	TAF 425230	—	—	130
		—	—	—	—	—	113
	—	RNA 6907	—	—	—	—	200
42	—	—	—	—	TR 425630	—	183
	—	—	—	—	—	GTR 425630	210
43	—	—	—	TAF 435320	—	—	88.5
	—	—	—	TAF 435330	—	—	133
45	—	—	—	TAF 455520	—	—	92
	RNA 49/38	—	—	TAF 455530	—	—	138
		—	—	—	—	—	120
	—	—	—	—	TR 455930	—	193
—	—	—	—	—	GTR 455930	225	
47	—	—	—	TAF 475720	—	—	95
	—	—	—	TAF 475730	—	—	144
48	RNA 4908	—	—	—	—	—	152
	—	—	—	—	TR 486230	—	205
	—	RNA 6908	—	—	—	—	275
	—		—	—	—	GTR 486230	240
50	—	—	—	TAF 506225	—	—	159
	—	—	—	TAF 506235	—	—	225
	—	—	—	—	TR 506430	—	210
	RNA 49/42	—	—	—	—	—	174
—	—	—	—	—	GTR 506430	245	

Notes⁽¹⁾ Minimum allowable value of chamfer dimension r
⁽²⁾ Allowable rotational speed applies to oil lubrication. For grease lubrication, a maximum of 60% of this value is allowable.
 Remarks1. The outer ring has an oil groove and an oil hole.
 2. No grease is prepacked. Perform proper lubrication.

Boundary dimensions mm				Standard mounting dimension	Basic dynamic load rating	Basic static load rating	Allowable rotational speed ⁽²⁾
F_w	D	C	$r_{s \min}^{(1)}$	D_a Max. mm	C N	C_0 N	rpm
42	52	20	0.3	50	29 900	56 200	9 500
42	52	30	0.3	50	43 000	89 400	9 500
42	55	20	0.6	51	32 000	50 100	9 500
42	55	36	0.6	51	54 900	100 000	9 500
42	56	30	0.6	52	53 800	90 100	9 500
42	56	30	0.6	52	67 500	133 000	3 500
43	53	20	0.3	51	30 500	58 200	9 500
43	53	30	0.3	51	43 800	92 600	9 500
45	55	20	0.3	53	31 000	60 200	9 000
45	55	30	0.3	53	44 600	95 800	9 000
45	58	20	0.6	54	33 600	54 600	9 000
45	59	30	0.6	55	55 100	94 800	9 000
45	59	30	0.6	55	70 300	142 000	3 500
47	57	20	0.3	55	31 500	62 200	8 500
47	57	30	0.3	55	45 200	99 100	8 500
48	62	22	0.6	58	41 600	67 400	8 500
48	62	30	0.6	58	56 300	95 500	8 500
48	62	40	0.6	58	71 300	135 000	8 500
48	62	30	0.6	58	72 700	154 000	3 000
50	62	25	0.3	60	43 000	85 300	8 000
50	62	35	0.3	60	58 000	125 000	8 000
50	64	30	0.6	60	57 700	104 000	8 000
50	65	22	0.6	61	42 500	70 300	8 000
50	64	30	0.6	60	74 600	158 000	3 000

D

**NA
TAF
TRI
BRI**

MACHINED TYPE NEEDLE ROLLER BEARINGS

Without Inner Ring

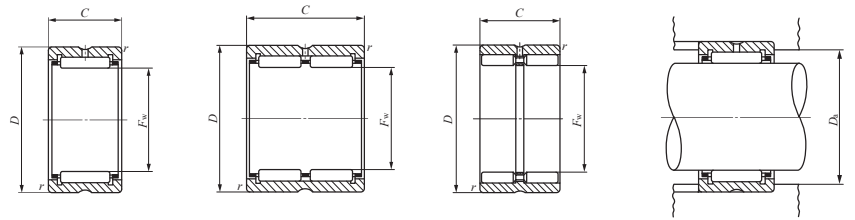

RNA49 TAF TR

RNA69

GTR

Shaft dia. 52 – 68mm

Shaft dia. mm	Identification number						Mass (Ref.) g
	RNA 49	RNA 69	RNA 48	TAF	TR	GTR	
52	RNA 4909	—	—	—	—	—	197
	—	RNA 6909	—	—	—	—	355
55	—	—	—	TAF 556825	—	—	193
	—	—	—	TAF 556835	—	—	255
	RNA 49/48	—	—	—	—	—	188
58	RNA 4910	—	—	—	—	—	179
	—	RNA 6910	—	—	—	—	320
60	—	—	—	TAF 607225	—	—	187
	—	—	—	TAF 607235	—	—	260
	RNA 49/52	—	—	—	—	—	205
62	—	—	—	—	TR 628138	—	460
	—	—	—	—	—	GTR 628138	520
63	RNA 4911	—	—	—	—	—	265
	—	RNA 6911	—	—	—	—	475
65	—	—	—	TAF 657825	—	—	225
	—	—	—	TAF 657835	—	—	315
	RNA 49/58	—	—	—	—	—	275
68	—	—	—	TAF 688225	—	—	250
	—	—	—	TAF 688235	—	—	350
	RNA 4912	—	—	—	—	—	285
	—	RNA 6912	—	—	—	—	510

Notes⁽¹⁾ Minimum allowable value of chamfer dimension r
⁽²⁾ Allowable rotational speed applies to oil lubrication. For grease lubrication, a maximum of 60% of this value is allowable.
 Remarks1. The outer ring has an oil groove and an oil hole.
 2. No grease is prepacked. Perform proper lubrication.

Boundary dimensions mm				Standard mounting dimension D_a Max. mm	Basic dynamic load rating C N	Basic static load rating C_0 N	Allowable rotational speed ⁽²⁾ rpm
F_w	D	C	$r_{s \min}^{(1)}$				
52	68	22	0.6	64	43 500	73 300	7 500
52	68	40	0.6	64	74 600	147 000	7 500
55	68	25	0.3	66	45 400	94 000	7 500
55	68	35	0.3	66	61 200	138 000	7 500
55	70	22	0.6	66	44 300	76 300	7 500
58	72	22	0.6	68	46 200	82 100	7 000
58	72	40	0.6	68	79 200	164 000	7 000
58	77	45	1	72	104 000	191 000	7 000
58	77	45	1	72	135 000	280 000	2 500
60	72	25	0.3	70	47 500	103 000	6 500
60	72	35	0.3	70	64 100	151 000	6 500
60	75	22	0.6	71	47 100	85 100	6 500
62	81	38	1	76	92 000	166 000	6 500
62	81	38	1	76	118 000	241 000	2 500
63	80	25	1	75	57 600	97 200	6 500
63	80	45	1	75	98 700	194 000	6 500
65	78	25	0.6	74	49 600	112 000	6 000
65	78	35	0.6	74	67 000	164 000	6 000
65	82	25	1	77	58 900	101 000	6 000
68	82	25	0.6	78	54 800	117 000	6 000
68	82	35	0.6	78	72 000	166 000	6 000
68	85	25	1	80	60 200	105 000	6 000
68	85	45	1	80	103 000	211 000	6 000

D

NA
TAF
TRI
BRI

MACHINED TYPE NEEDLE ROLLER BEARINGS

Without Inner Ring

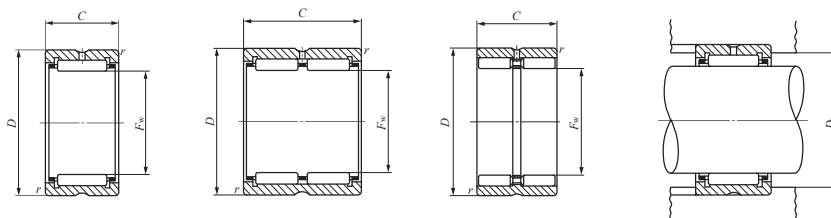

RNA49 TAF TR

RNA69

GTR

Shaft dia. 70 – 85mm

Shaft dia. mm	Identification number						Mass (Ref.) g
	RNA 49	RNA 69	RNA 48	TAF	TR	GTR	
70	—	—	—	TAF 708525	—	—	280
	—	—	—	TAF 708535	—	—	395
	RNA 49/62	—	—	—	—	—	320
70	—	—	—	—	TR 708945	—	605
	—	—	—	—	—	GTR 708945	690
72	RNA 4913	—	—	—	—	—	325
	—	RNA 6913	—	—	—	—	585
73	—	—	—	TAF 739025	—	—	335
	—	—	—	TAF 739035	—	—	475
75	—	—	—	TAF 759225	—	—	345
	—	—	—	TAF 759235	—	—	485
	RNA 49/68	—	—	—	—	—	470
80	—	—	—	TAF 809525	—	—	315
	RNA 4914	—	—	TAF 809535	—	—	445
	—	RNA 6914	—	—	—	—	495
83	—	—	—	—	TR 8310845	—	995
	—	—	—	—	—	GTR 8310845	1 090
85	—	—	—	TAF 8510525	—	—	435
	RNA 4915	—	—	—	—	—	525
	—	—	—	TAF 8510535	—	—	610
	—	RNA 6915	—	—	—	—	960

Notes⁽¹⁾ Minimum allowable value of chamfer dimension r
⁽²⁾ Allowable rotational speed applies to oil lubrication. For grease lubrication, a maximum of 60% of this value is allowable.
 Remarks1. The outer ring has an oil groove and an oil hole.
 2. No grease is prepacked. Perform proper lubrication.

Boundary dimensions mm				Standard mounting dimension	Basic dynamic load rating	Basic static load rating	Allowable rotational speed ⁽²⁾ rpm
F_w	D	C	r_s min ⁽¹⁾	D_a Max. mm	C N	C_0 N	
70	85	25	0.6	81	55 500	120 000	5 500
70	85	35	0.6	81	73 000	171 000	5 500
70	88	25	1	83	61 500	109 000	5 500
70	89	45	1	84	114 000	228 000	5 500
70	89	45	1	84	147 000	336 000	2 000
72	90	25	1	85	62 700	113 000	5 500
72	90	45	1	85	108 000	227 000	5 500
73	90	25	1	85	61 100	127 000	5 500
73	90	35	1	85	80 400	181 000	5 500
75	92	25	1	87	62 100	131 000	5 500
75	92	35	1	87	81 700	186 000	5 500
75	95	30	1	90	79 900	147 000	5 500
80	95	25	1	90	59 400	137 000	5 000
80	95	35	1	90	78 100	195 000	5 000
80	100	30	1	95	83 200	158 000	5 000
80	100	54	1	95	134 000	311 000	5 000
83	108	45	1	103	146 000	270 000	5 000
83	108	45	1	103	190 000	396 000	1 800
85	105	25	1	100	76 300	145 000	4 500
85	105	30	1	100	86 200	169 000	4 500
85	105	35	1	100	102 000	210 000	4 500
85	105	54	1	100	138 000	331 000	4 500

D
 NA
 TAF
 TRI
 BRI

MACHINED TYPE NEEDLE ROLLER BEARINGS

Without Inner Ring

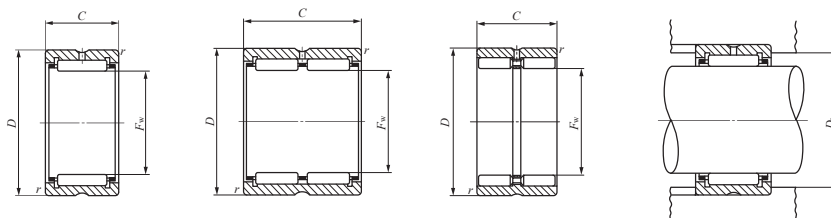

RNA49 TAF TR

RNA69

GTR

Shaft dia. 90 – 105mm

Shaft dia. mm	Identification number						Mass (Ref.) g
	RNA 49	RNA 69	RNA 48	TAF	TR	GTR	
90	—	—	—	TAF 9011025	—	—	455
	RNA 4916	—	—	—	—	—	550
	—	—	—	TAF 9011035	—	—	640
	—	RNA 6916	—	—	—	—	1 010
93	—	—	—	—	TR 9311850	—	1 210
	—	—	—	—	—	GTR 9311850	1 340
95	—	—	—	TAF 9511526	—	—	495
	RNA 49/82	—	—	—	—	—	575
	—	—	—	TAF 9511536	—	—	690
	—	—	—	—	TR 9512045	—	1 120
100	—	—	—	—	—	GTR 9512045	1 230
	—	—	—	TAF 10012026	—	—	525
	RNA 4917	—	—	—	—	—	705
	—	—	—	TAF 10012036	—	—	725
105	—	—	—	—	—	—	1 300
	—	—	—	—	TR 10012550	—	1 290
	—	—	—	—	—	GTR 10012550	1 440
	—	—	—	TAF 10512526	—	—	545
105	RNA 4918	—	—	—	—	—	740
	—	—	—	TAF 10512536	—	—	760
	—	—	—	—	—	—	1 360
	—	RNA 6918	—	—	—	—	1 360

Notes⁽¹⁾ Minimum allowable value of chamfer dimension r
⁽²⁾ Allowable rotational speed applies to oil lubrication. For grease lubrication, a maximum of 60% of this value is allowable.
 Remarks1. The outer ring has an oil groove and an oil hole.
 2. No grease is prepacked. Perform proper lubrication.

Boundary dimensions mm				Standard mounting dimension	Basic dynamic load rating	Basic static load rating	Allowable rotational speed ⁽²⁾
F_w	D	C	$r_{s \min}^{(1)}$	D_a Max. mm	C N	C_0 N	rpm
90	110	25	1	105	77 300	150 000	4 500
90	110	30	1	105	87 300	175 000	4 500
90	110	35	1	105	103 000	217 000	4 500
90	110	54	1	105	143 000	351 000	4 500
93	118	50	1	113	165 000	329 000	4 500
93	118	50	1	113	224 000	509 000	1 600
95	115	26	1	110	79 700	159 000	4 000
95	115	30	1	110	90 000	186 000	4 000
95	115	36	1	110	106 000	231 000	4 000
95	120	45	1.5	112	155 000	305 000	4 000
95	120	45	1.5	112	204 000	455 000	1 600
100	120	26	1	115	82 400	168 000	4 000
100	120	35	1.1	113.5	110 000	244 000	4 000
100	120	36	1	115	110 000	244 000	4 000
100	120	63	1.1	113.5	173 000	467 000	4 000
100	125	50	1.5	117	172 000	355 000	4 000
100	125	50	1.5	117	234 000	549 000	1 500
105	125	26	1	120	84 700	178 000	4 000
105	125	35	1.1	118.5	113 000	258 000	4 000
105	125	36	1	120	113 000	258 000	4 000
105	125	63	1.1	118.5	178 000	490 000	4 000

D
 NA
 TAF
 TRI
 BRI

MACHINED TYPE NEEDLE ROLLER BEARINGS

Without Inner Ring

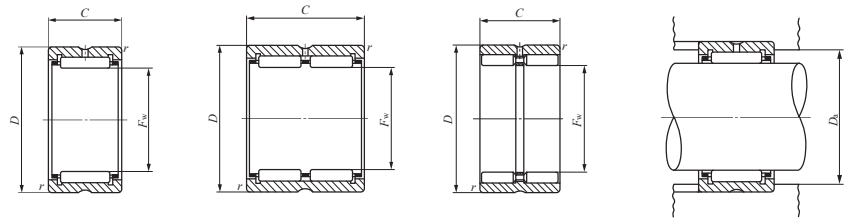

RNA49 RNA48
TAF TR

RNA69

GTR

Shaft dia. 110 – 170mm

Shaft dia. mm	Identification number						Mass (Ref.) g
	RNA 49	RNA 69	RNA 48	TAF	TR	GTR	
110	—	—	—	TAF 11013030	—	—	660
	RNA 4919	—	—	—	—	—	770
	—	—	—	TAF 11013040	—	—	880
	—	RNA 6919	—	—	—	—	1 420
115	—	—	—	—	TR 11013550	—	1 400
	—	—	—	—	—	GTR 11013550	1 560
120	RNA 4920	—	—	—	—	—	1 190
	—	—	—	—	TR 11515350	—	2 350
	—	—	—	—	—	GTR 11515350	2 600
125	—	—	RNA 4822	—	—	—	790
125	RNA 4922	—	—	—	—	—	1 280
130	—	—	RNA 4824	—	—	—	850
135	RNA 4924	—	—	—	—	—	1 930
140	—	—	—	—	TR 14017860	—	3 320
	—	—	—	—	—	GTR 14017860	3 730
145	—	—	RNA 4826	—	—	—	1 100
150	RNA 4926	—	—	—	—	—	2 360
	—	—	—	—	TR 15018860	—	3 540
	—	—	—	—	—	GTR 15018860	3 970
155	—	—	RNA 4828	—	—	—	1 170
160	RNA 4928	—	—	—	—	—	2 500
165	—	—	RNA 4830	—	—	—	1 750
170	RNA 4930	—	—	—	—	—	4 090

Notes⁽¹⁾ Minimum allowable value of chamfer dimension *r*
⁽²⁾ Allowable rotational speed applies to oil lubrication. For grease lubrication, a maximum of 60% of this value is allowable.
 Remarks1. The outer ring has an oil groove and an oil hole.
 2. No grease is prepacked. Perform proper lubrication.

Boundary dimensions mm				Standard mounting dimension	Basic dynamic load rating	Basic static load rating	Allowable rotational speed ⁽²⁾
F_w	D	C	$r_{s \min}^{(1)}$	D_a Max. mm	C N	C_0 N	rpm
110	130	30	1	125	106 000	240 000	3 500
110	130	35	1.1	123.5	116 000	271 000	3 500
110	130	40	1	125	134 000	324 000	3 500
110	130	63	1.1	123.5	182 000	514 000	3 500
110	135	50	1.5	127	183 000	395 000	3 500
110	135	50	1.5	127	245 000	603 000	1 400
115	140	40	1.1	133.5	145 000	329 000	3 500
115	153	50	1.5	145	233 000	414 000	3 500
115	153	50	1.5	145	315 000	614 000	1 300
120	140	30	1	135	93 200	239 000	3 500
125	150	40	1.1	143.5	152 000	357 000	3 000
130	150	30	1	145	96 900	259 000	3 000
135	165	45	1.1	158.5	187 000	435 000	3 000
140	178	60	1.5	170	307 000	625 000	3 000
140	178	60	1.5	170	409 000	923 000	1 100
145	165	35	1.1	158.5	116 000	340 000	3 000
150	180	50	1.5	172	215 000	540 000	2 500
150	188	60	1.5	180	320 000	675 000	2 500
150	188	60	1.5	180	423 000	989 000	1 000
155	175	35	1.1	168.5	120 000	363 000	2 500
160	190	50	1.5	182	224 000	580 000	2 500
165	190	40	1.1	183.5	168 000	446 000	2 500
170	210	60	2	201	324 000	712 000	2 500

D

NA
TAFI
TRI
BRI

MACHINED TYPE NEEDLE ROLLER BEARINGS

Without Inner Ring



Shaft dia. 175 – 350mm

Shaft dia. mm	Identification number						Mass (Ref.) g
	RNA 49	RNA 69	RNA 48	TAF	TR	GTR	
175	—	—	RNA 4832	—	—	—	1 850
180	RNA 4932	—	—	—	—	—	4 310
185	—	—	RNA 4834	—	—	—	2 700
190	RNA 4934	—	—	—	—	—	4 530
195	—	—	RNA 4836	—	—	—	2 840
205	RNA 4936	—	—	—	—	—	6 250
210	—	—	RNA 4838	—	—	—	3 380
215	RNA 4938	—	—	—	—	—	6 500
220	—	—	RNA 4840	—	—	—	3 520
225	RNA 4940	—	—	—	—	—	10 400
240	—	—	RNA 4844	—	—	—	3 820
245	RNA 4944	—	—	—	—	—	11 200
265	—	—	RNA 4848	—	—	—	5 670
	RNA 4948	—	—	—	—	—	12 000
285	—	—	RNA 4852	—	—	—	6 070
290	RNA 4952	—	—	—	—	—	21 200
305	—	—	RNA 4856	—	—	—	9 750
310	RNA 4956	—	—	—	—	—	22 500
330	—	—	RNA 4860	—	—	—	13 200
340	RNA 4960	—	—	—	—	—	33 400
350	—	—	RNA 4864	—	—	—	14 100

Notes⁽¹⁾ Minimum allowable value of chamfer dimension r
⁽²⁾ Allowable rotational speed applies to oil lubrication. For grease lubrication, a maximum of 60% of this value is allowable.
 Remarks1. The outer ring has an oil groove and an oil hole.
 2. No grease is prepacked. Perform proper lubrication.

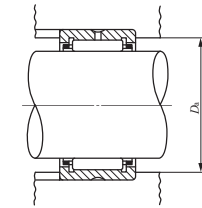
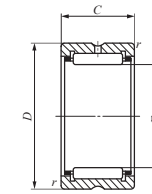

RNA49 RNA48

Boundary dimensions mm				Standard mounting dimension	Basic dynamic load rating	Basic static load rating	Allowable rotational speed ⁽²⁾
F_w	D	C	$r_{s \min}^{(1)}$	D_a Max. mm	C N	C_0 N	rpm
175	200	40	1.1	193.5	173 000	474 000	2 500
180	220	60	2	211	337 000	761 000	1 900
185	215	45	1.1	208.5	211 000	567 000	1 900
190	230	60	2	221	347 000	810 000	1 900
195	225	45	1.1	218.5	218 000	602 000	1 900
205	250	69	2	241	434 000	989 000	1 900
210	240	50	1.5	232	249 000	726 000	1 800
215	260	69	2	251	440 000	1 020 000	1 700
220	250	50	1.5	242	255 000	766 000	1 600
225	280	80	2.1	269	518 000	1 120 000	1 600
240	270	50	1.5	262	266 000	833 000	1 500
245	300	80	2.1	289	536 000	1 200 000	1 400
265	300	60	2	291	345 000	1 150 000	1 300
265	320	80	2.1	309	565 000	1 320 000	1 300
285	320	60	2	311	354 000	1 220 000	1 100
290	360	100	2.1	349	847 000	1 900 000	1 100
305	350	69	2	341	486 000	1 550 000	950
310	380	100	2.1	369	877 000	2 040 000	950
330	380	80	2.1	369	610 000	1 900 000	900
340	420	118	3	407	1 130 000	2 650 000	850
350	400	80	2.1	389	635 000	2 040 000	750

D
 NA
 TAF
 TRI
 BRI

MACHINED TYPE NEEDLE ROLLER BEARINGS

Without Inner Ring

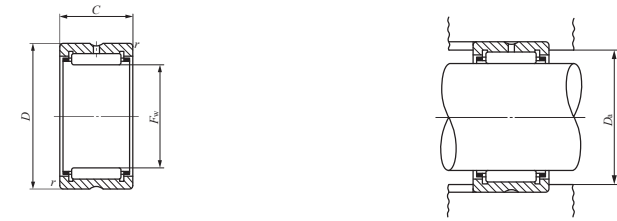

RNA49 RNA48

Shaft dia. 360 – 490mm

Shaft dia. mm	Identification number						Mass (Ref.) g
	RNA 49	RNA 69	RNA 48	TAF	TR	GTR	
360	RNA 4964	—	—	—	—	—	35 200
370	—	—	RNA 4868	—	—	—	14 800
380	RNA 4968	—	—	—	—	—	37 000
390	—	—	RNA 4872	—	—	—	15 600
400	RNA 4972	—	—	—	—	—	38 700
415	—	—	RNA 4876	—	—	—	27 900
430	RNA 4976	—	—	—	—	—	56 400
450	RNA 4980	—	—	—	—	—	58 800
470	RNA 4984	—	—	—	—	—	61 200
490	RNA 4988	—	—	—	—	—	86 900

Notes⁽¹⁾ Minimum allowable value of chamfer dimension *r*
⁽²⁾ Allowable rotational speed applies to oil lubrication. For grease lubrication, a maximum of 60% of this value is allowable.
 Remarks1. The outer ring has an oil groove and an oil hole.
 2. No grease is prepacked. Perform proper lubrication.

Boundary dimensions mm				Standard mounting dimension <i>D_a</i> Max. mm	Basic dynamic load rating <i>C</i> N	Basic static load rating <i>C₀</i> N	Allowable rotational speed ⁽²⁾ rpm
<i>F_w</i>	<i>D</i>	<i>C</i>	<i>r_s</i> min ⁽¹⁾				
360	440	118	3	427	1 170 000	2 830 000	750
370	420	80	2.1	409	651 000	2 140 000	700
380	460	118	3	447	1 220 000	3 020 000	700
390	440	80	2.1	429	680 000	2 320 000	650
400	480	118	3	467	1 260 000	3 200 000	600
415	480	100	2.1	469	951 000	2 860 000	600
430	520	140	4	504	1 540 000	4 030 000	500
450	540	140	4	524	1 590 000	4 270 000	500
470	560	140	4	544	1 640 000	4 510 000	500
490	600	160	4	584	1 910 000	5 140 000	400

D

NA
TAFI
TRI
BRI

MACHINED TYPE NEEDLE ROLLER BEARINGS

With Inner Ring

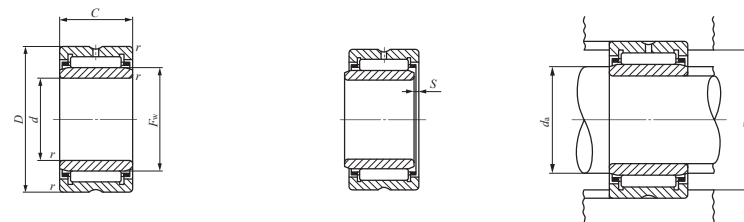

NA49 TAFI
NA69 ($d \leq 30$)

Shaft dia. 5 — 12mm

Shaft dia. mm	Identification number						Mass (Ref.) g	d
	NA 49	NA 69	NA 48	TAFI	TRI	GTRI		
5	NA 495	—	—	—	—	—	7.3	5
	—	—	—	TAFI 51512	—	—	11.9	5
	—	—	—	TAFI 51516	—	—	16.7	5
6	NA 496	—	—	—	—	—	9.1	6
	—	—	—	TAFI 61612	—	—	13	6
	—	—	—	TAFI 61616	—	—	17.5	6
7	NA 497	—	—	—	—	—	11.2	7
	—	—	—	TAFI 71712	—	—	14.3	7
	—	—	—	TAFI 71716	—	—	19.2	7
8	NA 498	—	—	—	—	—	15	8
9	—	—	—	TAFI 91912	—	—	16.7	9
	—	—	—	TAFI 91916	—	—	22.5	9
	NA 499	—	—	—	—	—	16.7	9
10	NA 4900	—	—	—	—	—	24	10
	—	—	—	TAFI 102216	—	—	30	10
	—	—	—	TAFI 102220	—	—	38	10
12	NA 4901	—	—	—	—	—	26.5	12
	—	—	—	TAFI 122416	—	—	33.5	12
	—	—	—	TAFI 122420	—	—	42.5	12
	—	NA 6901	—	—	—	—	44.5	12

Notes⁽¹⁾ Minimum allowable value of chamfer dimension r
⁽²⁾ Allowable axial shift amount of inner ring to outer ring
⁽³⁾ Allowable rotational speed applies to oil lubrication. For grease lubrication, a maximum of 60% of this value is allowable.
 Remarks1. TAFI series with a bore diameter d of 22 mm or less have no oil hole. In others, the outer ring has an oil groove and an oil hole.
 2. No grease is prepacked. Perform proper lubrication.

Boundary dimensions mm							Standard mounting dimensions mm			Basic dynamic load rating	Basic static load rating	Allowable rotational speed ⁽³⁾	Assembled inner ring
D	C	B	r_s min ⁽¹⁾	F_w	S ⁽²⁾	d_a	Min.	Max.	D_a Max.	C	C_0	rpm	
										N	N		
13	10	—	0.15	7	0.5	6.2	6.7	11.8	2 960	2 690	60 000	LRT 5710	
15	12	—	0.2	8	0.5	6.6	7.7	13.4	5 060	4 690	50 000	LRT 5812	
15	16	—	0.2	8	0.5	6.6	7.7	13.4	7 080	7 220	50 000	LRT 5816	
15	10	—	0.15	8	0.5	7.2	7.7	13.8	3 960	3 420	50 000	LRT 6810	
16	12	—	0.2	9	0.5	7.6	8.7	14.4	5 490	5 330	45 000	LRT 6912	
16	16	—	0.2	9	0.5	7.6	8.7	14.4	7 680	8 210	45 000	LRT 6916	
17	10	—	0.15	9	0.5	8.2	8.7	15.8	4 530	3 650	45 000	LRT 7910	
17	12	—	0.2	10	0.5	8.6	9.7	15.4	5 880	5 970	40 000	LRT 71012	
17	16	—	0.2	10	0.5	8.6	9.7	15.4	8 230	9 190	40 000	LRT 71016	
19	11	—	0.2	10	0.5	9.6	9.9	17.4	6 180	5 030	40 000	LRT 81011	
19	12	—	0.3	12	0.5	11	11.5	17	6 610	7 260	35 000	LRT 91212	
19	16	—	0.3	12	0.5	11	11.5	17	9 250	11 200	35 000	LRT 91216	
20	11	—	0.3	12	0.5	11	11.5	18	6 600	6 310	35 000	LRT 91211	
22	13	—	0.3	14	0.5	12	13	20	9 230	10 100	30 000	LRT 101413	
22	16	—	0.3	14	0.5	12	13	20	11 700	13 700	30 000	LRT 101416	
22	20	—	0.3	14	0.5	12	13	20	14 800	18 600	30 000	LRT 101420	
24	13	—	0.3	16	0.5	14	15	22	9 660	11 100	25 000	LRT 121613	
24	16	—	0.3	16	0.5	14	15	22	12 300	15 100	25 000	LRT 121616	
24	20	—	0.3	16	0.5	14	15	22	15 500	20 400	25 000	LRT 121620	
24	22	—	0.3	16	0.5	14	15	22	17 100	23 000	25 000	LRT 121622	

D
NA
TAFI
TRI
BRI

MACHINED TYPE NEEDLE ROLLER BEARINGS

With Inner Ring

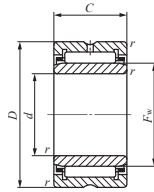

NA49 TAFI
NA69 ($d \leq 30$)

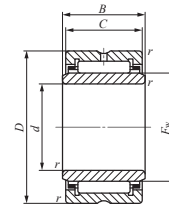

TRI

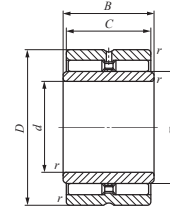

GTRI

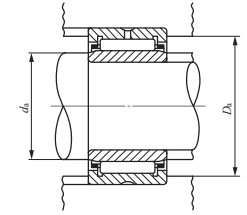
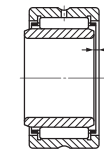

Shaft dia. 15 – 22mm

Shaft dia. mm	Identification number						Mass (Ref.) g	d
	NA 49	NA 69	NA 48	TAFI	TRI	GTRI		
15	—	—	—	TAFI 152716	—	—	39.5	15
	NA 4902	—	—	TAFI 152720	—	—	50	15
	—	NA 6902	—	—	—	—	35	15
	—	—	—	—	—	—	61	15
	—	—	—	—	TRI 153320	—	81	15
	—	—	—	—	—	GTRI 153320	90.5	15
17	—	—	—	TAFI 172916	—	—	43.5	17
	NA 4903	—	—	TAFI 172920	—	—	54	17
	—	NA 6903	—	—	—	—	39	17
	—	—	—	—	—	—	67	17
	—	—	—	—	TRI 173425	—	104	17
	—	—	—	—	—	GTRI 173425	117	17
20	—	—	—	TAFI 203216	—	—	48.5	20
	NA 4904	—	—	TAFI 203220	—	—	61	20
	—	NA 6904	—	—	—	—	78.5	20
	—	—	—	—	—	—	136	20
	—	—	—	—	TRI 203820	—	99	20
	—	—	—	—	TRI 203825	—	124	20
22	—	—	—	TAFI 223416	—	—	52	22
	NA 49/22	—	—	TAFI 223420	—	—	67.5	22
	—	—	—	—	—	—	87	22
	—	NA 69/22	—	—	—	—	152	22
	—	—	—	—	—	—	—	—
	—	—	—	—	—	—	—	—

Notes⁽¹⁾ Minimum allowable value of chamfer dimension r
⁽²⁾ Allowable axial shift amount of inner ring to outer ring
⁽³⁾ Allowable rotational speed applies to oil lubrication. For grease lubrication, a maximum of 60% of this value is allowable.
 Remarks¹. TAFI series with a bore diameter d of 22 mm or less have no oil hole. In others, the outer ring has an oil groove and an oil hole.
². No grease is prepacked. Perform proper lubrication.

Boundary dimensions mm						Standard mounting dimensions mm			Basic dynamic load rating C N	Basic static load rating C_0 N	Allowable rotational speed ⁽³⁾ rpm	Assembled inner ring
D	C	B	r_s min ⁽¹⁾	F_w ⁽²⁾	S ⁽²⁾	Min. d_a	Max.	D_a Max.				
27	16	—	0.3	19	0.5	17	18	25	14 000	18 700	20 000	LRT 151916
27	20	—	0.3	19	0.5	17	18	25	17 700	25 300	20 000	LRT 151920
28	13	—	0.3	20	0.3	17	19	26	10 900	13 800	20 000	LRT 152013
28	23	—	0.3	20	0.3	17	19	26	19 300	28 800	20 000	LRT 152023
33	20	20.5	0.3	20	0.3	17	19	31	24 300	26 500	20 000	LRT 152020
33	20	20.5	0.3	20	—	17	19	31	29 200	37 200	7 500	LRTZ 152020
29	16	—	0.3	21	0.5	19	20	27	14 400	20 000	19 000	LRT 172116
29	20	—	0.3	21	0.5	19	20	27	18 200	27 100	19 000	LRT 172120
30	13	—	0.3	22	0.3	19	21	28	11 700	15 600	18 000	LRT 172213
30	23	—	0.3	22	0.3	19	21	28	20 800	32 500	18 000	LRT 172223
34	25	25.5	0.3	22	0.5	19	21	32	29 100	36 800	18 000	LRT 172225
34	25	25.5	0.3	22	—	19	21	32	37 900	57 800	7 000	LRTZ 172225
32	16	—	0.3	24	0.5	22	23	30	15 300	22 500	17 000	LRT 202416
32	20	—	0.3	24	0.5	22	23	30	19 400	30 500	17 000	LRT 202420
37	17	—	0.3	25	0.5	22	24	35	21 000	25 000	16 000	LRT 202517
37	30	—	0.3	25	0.5	22	24	35	35 400	48 900	16 000	LRT 202530
38	20	20.5	0.3	25	0.3	22	24	36	28 900	35 000	16 000	LRT 202520
38	25	25.5	0.3	25	0.5	22	24	36	34 800	44 400	16 000	LRT 202525
38	20	20.5	0.3	25	—	22	24	36	33 300	46 500	6 000	LRTZ 202520
38	25	25.5	0.3	25	—	22	24	36	42 400	63 700	6 000	LRTZ 202525
34	16	—	0.3	26	0.5	24	25	32	16 300	24 900	15 000	LRT 222616
34	20	—	0.3	26	0.5	24	25	32	20 600	33 800	15 000	LRT 222620
39	17	—	0.3	28	1	24	27	37	21 400	28 900	14 000	LRT 222817
39	30	—	0.3	28	0.5	24	27	37	36 300	56 900	14 000	LRT 222830

D
NA
TAFI
TRI
BRI

MACHINED TYPE NEEDLE ROLLER BEARINGS

With Inner Ring

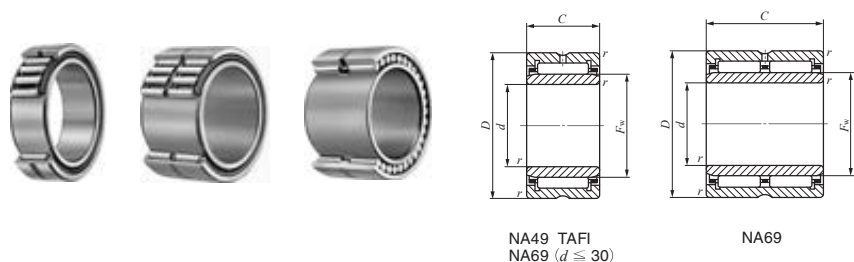

NA49 TAFI
NA69 ($d \leq 30$)

NA69

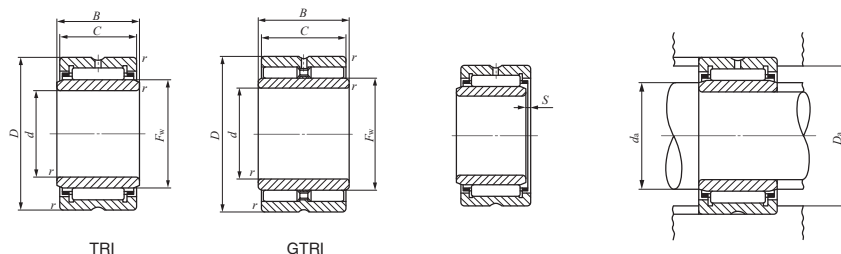

TRI

GTRI

Shaft dia. 25 – 32mm

Shaft dia. mm	Identification number						Mass (Ref.)	d
	NA 49	NA 69	NA 48	TAFI	TRI	GTRI	g	
25	—	—	—	TAFI 253820	—	—	82	25
	NA 4905	—	—	TAFI 253830	—	—	123	25
	—	NA 6905	—	—	—	—	92.5	25
	—	—	—	—	—	—	160	25
28	—	—	—	—	TRI 254425	—	157	25
	—	—	—	—	—	GTRI 254425	175	25
	—	—	—	TAFI 284220	—	—	96.5	28
	NA 49/28	—	—	TAFI 284230	—	—	145	28
30	—	—	—	—	—	—	101	28
	—	NA 69/28	—	—	—	—	176	28
	—	—	—	—	—	GTRI 284530	196	28
	—	—	—	TAFI 304520	—	—	112	30
32	NA 4906	—	—	TAFI 304530	—	—	171	30
	—	NA 6906	—	—	—	—	106	30
	—	—	—	—	TRI 304830	—	199	30
	—	—	—	—	—	GTRI 304830	225	30
32	—	—	—	TAFI 324720	—	—	121	32
	NA 49/32	—	—	TAFI 324730	—	—	180	32
	—	—	—	—	—	—	165	32
	—	NA 69/32	—	—	TRI 325230	—	245	32
32	—	—	—	—	—	—	295	32
	—	—	—	—	—	GTRI 325230	270	32
	—	—	—	—	—	—	—	—
	—	—	—	—	—	—	—	—

Notes⁽¹⁾ Minimum allowable value of chamfer dimension r
⁽²⁾ Allowable axial shift amount of inner ring to outer ring
⁽³⁾ Allowable rotational speed applies to oil lubrication. For grease lubrication, a maximum of 60% of this value is allowable.
 Remarks1. The outer ring has an oil groove and an oil hole.
 2. No grease is prepacked. Perform proper lubrication.

Boundary dimensions mm						Standard mounting dimensions mm			Basic dynamic load rating	Basic static load rating	Allowable rotational speed ⁽³⁾	Assembled inner ring
D	C	B	r _{s min} ⁽¹⁾	F _w ⁽²⁾	S	Min. d _a	Max.	D _a Max.	C	C ₀	rpm	
38	20	—	0.3	29	0.5	27	28	36	21 600	37 200	14 000	LRT 252920
38	30	—	0.3	29	1	27	28	36	30 900	59 100	14 000	LRT 252930
42	17	—	0.3	30	0.5	27	29	40	23 700	30 700	13 000	LRT 253017
42	30	—	0.3	30	0.5	27	29	40	42 100	64 300	13 000	LRT 253030
44	25	25.5	0.3	30	0.5	27	29	42	37 900	52 100	13 000	LRT 253025
44	25	25.5	0.3	30	—	27	29	42	47 000	76 500	5 000	LRTZ 253025
42	20	—	0.3	32	0.5	30	31	40	25 700	42 200	12 000	LRT 283220
42	30	—	0.3	32	1	30	31	40	36 800	67 200	12 000	LRT 283230
45	17	—	0.3	32	1	30	31	43	24 500	32 700	12 000	LRT 283217
45	30	—	0.3	32	1	30	31	43	41 800	64 800	12 000	LRT 283230
45	30	30.5	0.3	32	—	30	31	43	58 000	101 000	4 500	LRTZ 283230
45	20	—	0.3	35	0.3	32	34	43	26 900	46 200	11 000	LRT 303520
45	30	—	0.3	35	0.5	32	34	43	38 600	73 600	11 000	LRT 303530
47	17	—	0.3	35	0.5	32	34	45	25 200	34 700	11 000	LRT 303517
47	30	—	0.3	35	0.5	32	34	45	43 000	69 000	11 000	LRT 303530
48	30	30.5	0.3	35	1	32	34	46	47 400	72 300	11 000	LRT 303530-1
48	30	30.5	0.3	35	—	32	34	46	61 100	110 000	4 500	LRTZ 303530
47	20	—	0.3	37	0.3	34	36	45	28 200	50 100	11 000	LRT 323720
47	30	—	0.3	37	0.5	34	36	45	40 500	79 800	11 000	LRT 323730
52	20	—	0.6	40	0.5	36	39	48	31 200	47 800	10 000	LRT 324020
52	30	30.5	0.6	38	0.5	36	37	48	50 800	81 100	11 000	LRT 323830
52	36	—	0.6	40	0.3	36	39	48	53 500	95 700	10 000	LRT 324036
52	30	30.5	0.6	38	—	36	37	48	64 200	121 000	4 000	LRTZ 323830

D
NA
TAFI
TRI
BRI

MACHINED TYPE NEEDLE ROLLER BEARINGS

With Inner Ring

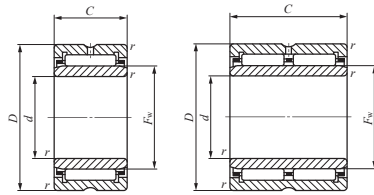

NA49 TAFI

NA69

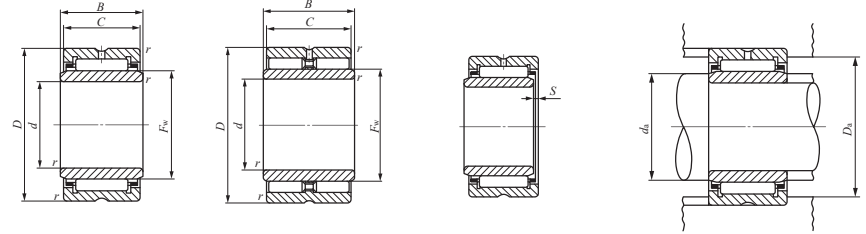

TRI

GTRI

Shaft dia. 35 – 45mm

Shaft dia. mm	Identification number						Mass (Ref.) g	d
	NA 49	NA 69	NA 48	TAFI	TRI	GTRI		
35	—	—	—	TAFI 355020	—	—	129	35
	NA 4907	—	—	TAFI 355030	—	—	192	35
	—	NA 6907	—	—	—	—	178	35
	—	—	—	—	—	—	320	35
38	—	—	—	TAFI 385320	—	—	136	38
	—	—	—	TAFI 385330	—	—	205	38
	—	—	—	—	TRI 355630	—	280	35
	—	—	—	—	—	GTRI 355520	191	35
40	—	—	—	TAFI 405520	—	—	143	40
	—	—	—	TAFI 405530	—	—	215	40
	NA 4908	—	—	—	TRI 405930	—	270	40
	—	NA 6908	—	—	—	—	245	40
42	—	—	—	TAFI 425720	—	—	149	42
	—	—	—	TAFI 425730	—	—	225	42
	—	—	—	—	TRI 426230	—	305	42
	—	—	—	—	—	GTRI 426230	340	42
45	—	—	—	TAFI 456225	—	—	230	45
	—	—	—	TAFI 456235	—	—	320	45
	NA 4909	—	—	—	TRI 456430	—	300	45
	—	NA 6909	—	—	—	—	285	45
45	—	—	—	—	—	—	520	45
	—	—	—	—	—	—	335	45
	—	—	—	—	—	—	—	—
	—	—	—	—	—	GTRI 456430	—	—

Notes⁽¹⁾ Minimum allowable value of chamfer dimension r
⁽²⁾ Allowable axial shift amount of inner ring to outer ring
⁽³⁾ Allowable rotational speed applies to oil lubrication. For grease lubrication, a maximum of 60% of this value is allowable.
 Remarks1. The outer ring has an oil groove and an oil hole.
 2. No grease is prepacked. Perform proper lubrication.

Boundary dimensions mm						Standard mounting dimensions mm			Basic dynamic load rating C N	Basic static load rating C ₀ N	Allowable rotational speed ⁽³⁾ rpm	Assembled inner ring
D	C	B	r _{s min} ⁽¹⁾	F _w ⁽²⁾	S ⁽²⁾	Min. d _a	Max.	D _a Max.				
50	20	—	0.3	40	0.3	37	39	48	29 400	54 100	10 000	LRT 354020
50	30	—	0.3	40	0.5	37	39	48	42 300	86 200	10 000	LRT 354030
55	20	—	0.6	42	0.5	39	41	51	32 000	50 100	9 500	LRT 354220
55	36	—	0.6	42	0.3	39	41	51	54 900	100 000	9 500	LRT 354236
56	30	30.5	0.6	42	0.5	39	41	52	53 800	90 100	9 500	LRT 354230
55	20	20.5	0.6	40	—	39	39.5	51	44 300	73 600	3 500	LRTZ 354020
56	30	30.5	0.6	42	—	39	41	52	67 500	133 000	3 500	LRTZ 354230
53	20	—	0.3	43	0.3	40	42	51	30 500	58 200	9 500	LRT 384320
53	30	—	0.3	43	0.5	40	42	51	43 800	92 600	9 500	LRT 384330
55	20	—	0.3	45	0.3	42	44	53	31 000	60 200	9 000	LRT 404520
55	30	—	0.3	45	0.5	42	44	53	44 600	95 800	9 000	LRT 404530
59	30	30.5	0.6	45	1	44	44.5	55	55 100	94 800	9 000	LRT 404530-1
62	22	—	0.6	48	0.5	44	47	58	41 600	67 400	8 500	LRT 404822
62	40	—	0.6	48	0.3	44	47	58	71 300	135 000	8 500	LRT 404840
59	30	30.5	0.6	45	—	44	44.5	55	70 300	142 000	3 500	LRTZ 404530
57	20	—	0.3	47	0.3	44	46	55	31 500	62 200	8 500	LRT 424720
57	30	—	0.3	47	0.5	44	46	55	45 200	99 100	8 500	LRT 424730
62	30	30.5	0.6	48	0.5	46	47	58	56 300	99 500	8 500	LRT 424830
62	30	30.5	0.6	48	—	46	47	58	72 700	154 000	3 000	LRTZ 424830
62	25	—	0.3	50	0.5	47	49	60	43 000	85 300	8 000	LRT 455025
62	35	—	0.3	50	1	47	49	60	58 000	125 000	8 000	LRT 455035
64	30	30.5	0.6	50	1	49	49.5	60	57 700	104 000	8 000	LRT 455030
68	22	—	0.6	52	0.5	49	51	64	43 500	73 300	7 500	LRT 455222
68	40	—	0.6	52	0.3	49	51	64	74 600	147 000	7 500	LRT 455240
64	30	30.5	0.6	50	—	49	49.5	60	74 600	158 000	3 000	LRTZ 455030

D

NA
TAFI
TRI
BRI

MACHINED TYPE NEEDLE ROLLER BEARINGS

With Inner Ring

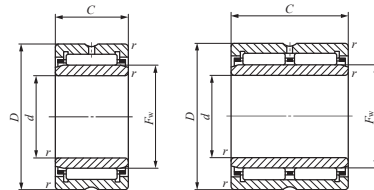

NA49 TAFI

NA69

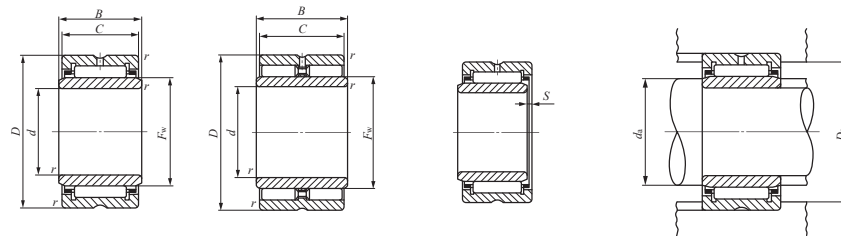

TRI

GTRI

Shaft dia. 50 – 70mm

Shaft dia. mm	Identification number						Mass (Ref.)	
	NA 49	NA 69	NA 48	TAFI	TRI	GTRI	g	d
50	—	—	—	TAFI 506825	—	—	270	50
	NA 4910	—	—	TAFI 506835	—	—	365	50
	—	NA 6910	—	—	—	—	295	50
	—	—	—	—	—	—	530	50
55	—	—	—	—	TRI 507745	—	755	50
	—	—	—	—	—	GTRI 507745	825	50
60	—	—	—	TAFI 557225	—	—	275	55
	NA 4911	—	—	TAFI 557235	—	—	380	55
	—	NA 6911	—	—	—	—	410	55
	—	—	—	—	—	—	730	55
65	—	—	—	—	TRI 558138	—	650	55
	—	—	—	—	—	GTRI 558138	710	55
	—	—	—	TAFI 608225	—	—	395	60
	NA 4912	—	—	TAFI 608235	—	—	560	60
70	—	—	—	—	—	—	440	60
	—	NA 6912	—	—	—	—	785	60
	—	—	—	—	TRI 608945	—	960	60
	—	—	—	—	—	GTRI 608945	1 050	60
65	NA 4913	—	—	—	—	—	470	65
	—	—	—	TAFI 659035	—	—	710	65
	—	NA 6913	—	—	—	—	840	65
70	—	—	—	TAFI 709525	—	—	540	70
	NA 4914	—	—	TAFI 709535	—	—	755	70
	—	—	—	—	—	—	765	70
	—	NA 6914	—	—	—	—	1 400	70

Notes⁽¹⁾ Minimum allowable value of chamfer dimension r
⁽²⁾ Allowable axial shift amount of inner ring to outer ring
⁽³⁾ Allowable rotational speed applies to oil lubrication. For grease lubrication, a maximum of 60% of this value is allowable.
 Remarks1. The outer ring has an oil groove and an oil hole.
 2. No grease is prepacked. Perform proper lubrication.

Boundary dimensions mm						Standard mounting dimensions mm			Basic dynamic load rating	Basic static load rating	Allowable rotational speed ⁽³⁾	Assembled inner ring
D	C	B	r _{s min} ⁽¹⁾	F _w	S ⁽²⁾	Min. d _a	Max.	D _a Max.	C	C ₀	rpm	
68	25	—	0.3	55	0.5	52	54	66	45 400	94 000	7 500	LRT 505525
68	35	—	0.3	55	1	52	54	66	61 200	138 000	7 500	LRT 505535
72	22	—	0.6	58	0.5	54	57	68	46 200	82 100	7 000	LRT 505822
72	40	—	0.6	58	0.3	54	57	68	79 200	164 000	7 000	LRT 505840
77	45	45.5	1	58	2	55	57	72	104 000	191 000	7 000	LRT 505845
77	45	45.5	1	58	—	55	57	72	135 000	280 000	2 500	LRTZ 505845
72	25	—	0.3	60	0.5	57	59	70	47 500	103 000	6 500	LRT 556025
72	35	—	0.3	60	1	57	59	70	64 100	151 000	6 500	LRT 556035
80	25	—	1	63	1	60	61	75	57 600	97 200	6 500	LRT 556325
80	45	—	1	63	0.5	60	61	75	98 700	194 000	6 500	LRT 556345
81	38	38.5	1	62	1.5	60	60.5	76	92 000	166 000	6 500	LRT 556238
81	38	38.5	1	62	—	60	60.5	76	118 000	241 000	2 500	LRTZ 556238
82	25	—	0.6	68	0.3	64	66	78	54 800	117 000	6 000	LRT 606825
82	35	—	0.6	68	1	64	66	78	72 000	166 000	6 000	LRT 606835
85	25	—	1	68	1	65	66	80	60 200	105 000	6 000	LRT 606825-1
85	45	—	1	68	0.5	65	66	80	103 000	211 000	6 000	LRT 606845
89	45	45.5	1	70	2	65	68	84	114 000	228 000	5 500	LRT 607045
89	45	45.5	1	70	—	65	68	84	147 000	336 000	2 000	LRTZ 607045
90	25	—	1	72	1	70	70.5	85	62 700	113 000	5 500	LRT 657225
90	35	—	1	73	1	70	71	85	80 400	181 000	5 500	LRT 657335
90	45	—	1	72	0.5	70	70.5	85	108 000	227 000	5 500	LRT 657245
95	25	—	1	80	0.3	75	78	90	59 400	137 000	5 000	LRT 708025
95	35	—	1	80	1	75	78	90	78 100	195 000	5 000	LRT 708035
100	30	—	1	80	1.5	75	78	95	83 200	158 000	5 000	LRT 708030
100	54	—	1	80	1	75	78	95	134 000	311 000	5 000	LRT 708054

D
NA
TAFI
TRI
BRI

MACHINED TYPE NEEDLE ROLLER BEARINGS

With Inner Ring

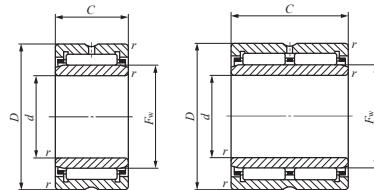

NA49 TAFI

NA69

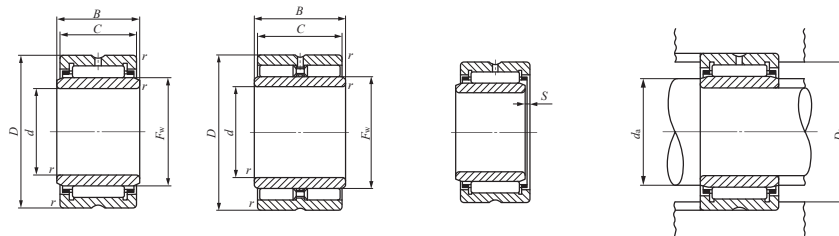

TRI

GTRI

Shaft dia. 75 – 90mm

Shaft dia. mm	Identification number						Mass (Ref.)	
	NA 49	NA 69	NA 48	TAFI	TRI	GTRI	g	d
75	—	—	—	TAFI 7510525	—	—	675	75
	NA 4915	—	—	—	—	—	810	75
	—	—	—	TAFI 7510535	—	—	945	75
	—	NA 6915	—	—	—	—	1 480	75
	—	—	—	—	TRI 7510845	—	1 340	75
	—	—	—	—	—	GTRI 7510845	1 440	75
80	—	—	—	TAFI 8011025	—	—	710	80
	NA 4916	—	—	—	—	—	855	80
	—	—	—	TAFI 8011035	—	—	995	80
	—	NA 6916	—	—	—	—	1 560	80
85	—	—	—	TAFI 8511526	—	—	775	85
	NA 4917	—	—	TAFI 8511536	—	—	1 080	85
	—	—	—	—	—	—	1 280	85
	—	NA 6917	—	—	—	—	2 340	85
	—	—	—	—	TRI 8511850	—	1 640	85
	—	—	—	—	TRI 8512045	—	1 610	85
90	—	—	—	TAFI 9012026	—	—	820	90
	NA 4918	—	—	TAFI 9012036	—	—	1 140	90
	—	—	—	—	—	—	1 350	90
	—	—	—	—	TRI 9012550	—	1 870	90
	—	NA 6918	—	—	—	—	2 460	90
	—	—	—	—	—	GTRI 9012550	2 020	90

Notes⁽¹⁾ Minimum allowable value of chamfer dimension r
⁽²⁾ Allowable axial shift amount of inner ring to outer ring
⁽³⁾ Allowable rotational speed applies to oil lubrication. For grease lubrication, a maximum of 60% of this value is allowable.
 Remarks1. The outer ring has an oil groove and an oil hole.
 2. No grease is prepacked. Perform proper lubrication.

Boundary dimensions mm						Standard mounting dimensions mm			Basic dynamic load rating	Basic static load rating	Allowable rotational speed ⁽³⁾	Assembled inner ring
D	C	B	r _{s min} ⁽¹⁾	F _w ⁽²⁾	S ⁽²⁾	Min. d _a	Max.	D _a Max.	C	C ₀	rpm	
									N	N		
105	25	—	1	85	0.5	80	83	100	76 300	145 000	4 500	LRT 758525
105	30	—	1	85	1.5	80	83	100	86 200	169 000	4 500	LRT 758530
105	35	—	1	85	1.5	80	83	100	102 000	210 000	4 500	LRT 758535
105	54	—	1	85	1	80	83	100	138 000	331 000	4 500	LRT 758554
108	45	45.5	1	83	2.5	80	81	103	146 000	270 000	5 000	LRT 758345
108	45	45.5	1	83	—	80	81	103	190 000	396 000	1 800	LRTZ 758345
110	25	—	1	90	0.5	85	88	105	77 300	150 000	4 500	LRT 809025
110	30	—	1	90	1.5	85	88	105	87 300	175 000	4 500	LRT 809030
110	35	—	1	90	1.5	85	88	105	103 000	217 000	4 500	LRT 809035
110	54	—	1	90	1	85	88	105	143 000	351 000	4 500	LRT 809054
115	26	—	1	95	1	90	93	110	79 700	159 000	4 000	LRT 859526
115	36	—	1	95	2	90	93	110	106 000	231 000	4 000	LRT 859536
120	35	—	1.1	100	1	91.5	98	113.5	110 000	244 000	4 000	LRT 8510035
120	63	—	1.1	100	0.5	91.5	98	113.5	173 000	467 000	4 000	LRT 8510063
118	50	50.5	1	93	3	90	91	113	165 000	329 000	4 500	LRT 859350
120	45	45.5	1.5	95	2.5	93	93.5	112	155 000	305 000	4 000	LRT 859545
118	50	50.5	1	93	—	90	91	113	224 000	509 000	1 600	LRTZ 859350
120	45	45.5	1.5	95	—	93	93.5	112	204 000	455 000	1 600	LRTZ 859545
120	26	—	1	100	1	95	98	115	82 400	168 000	4 000	LRT 9010026
120	36	—	1	100	2	95	98	115	110 000	244 000	4 000	LRT 9010036
125	35	—	1.1	105	1	96.5	103	118.5	113 000	258 000	4 000	LRT 9010535
125	50	50.5	1.5	100	3	98	98.5	117	172 000	355 000	4 000	LRT 9010050
125	63	—	1.1	105	0.5	96.5	103	118.5	178 000	490 000	4 000	LRT 9010563
125	50	50.5	1.5	100	—	98	98.5	117	234 000	549 000	1 500	LRTZ 9010050

D
NA
TAFI
TRI
BRI

MACHINED TYPE NEEDLE ROLLER BEARINGS

With Inner Ring

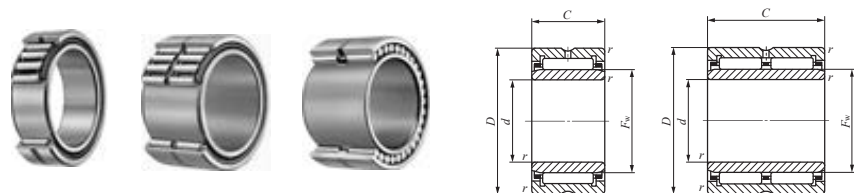

NA49 TAFI
NA48

NA69

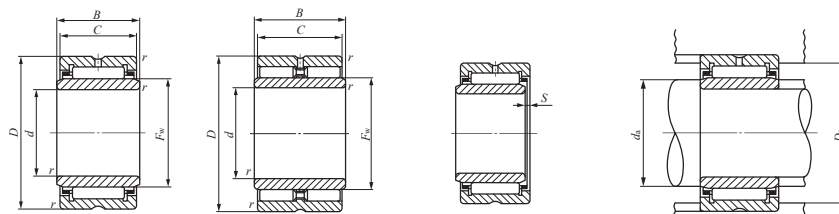

TRI

GTRI

D

NA
TAFI
TRI
BRI

Shaft dia. 95 – 150mm

Shaft dia. mm	Identification number						Mass (Ref.)	
	NA 49	NA 69	NA 48	TAFI	TRI	GTRI	g	d
95	—	—	—	TAFI 9512526	—	—	860	95
	NA 4919	—	—	TAFI 9512536	—	—	1 190	95
	—	NA 6919	—	—	—	—	1 420	95
100	—	—	—	TAFI 10013030	—	—	1 040	100
	—	—	—	TAFI 10013040	—	—	1 380	100
	NA 4920	—	—	—	TRI 10013550	—	2 040	100
105	—	—	—	—	—	GTRI 10013550	1 960	100
	—	—	—	—	TRI 10515350	—	3 020	105
	—	—	—	—	—	GTRI 10515350	3 270	105
110	—	—	NA 4822	—	—	—	1 200	110
	NA 4922	—	—	—	—	—	2 120	110
120	—	—	NA 4824	—	—	—	1 300	120
	NA 4924	—	—	—	—	—	2 960	120
125	—	—	—	—	TRI 12517860	—	4 780	125
	—	—	—	—	—	GTRI 12517860	5 180	125
130	—	—	NA 4826	—	—	—	1 960	130
	NA 4926	—	—	—	—	—	4 030	130
135	—	—	—	—	TRI 13518860	—	5 100	135
	—	—	—	—	—	GTRI 13518860	5 530	135
140	—	—	NA 4828	—	—	—	2 100	140
	NA 4928	—	—	—	—	—	4 290	140
150	—	—	NA 4830	—	—	—	2 880	150
	NA 4930	—	—	—	—	—	6 380	150

Notes⁽¹⁾ Minimum allowable value of chamfer dimension r
⁽²⁾ Allowable axial shift amount of inner ring to outer ring
⁽³⁾ Allowable rotational speed applies to oil lubrication. For grease lubrication, a maximum of 60% of this value is allowable.
 Remarks1. The outer ring has an oil groove and an oil hole.
 2. No grease is prepacked. Perform proper lubrication.

Boundary dimensions mm						Standard mounting dimensions mm			Basic dynamic load rating	Basic static load rating	Allowable rotational speed ⁽³⁾	Assembled inner ring
D	C	B	r _{s min} ⁽¹⁾	F _w	S ⁽²⁾	Min. d _a	Max. d _a	D _{a Max.}	C	C ₀	rpm	
									N	N		
125	26	—	1	105	1	100	103	120	84 700	178 000	4 000	LRT 9510526
125	36	—	1	105	2	100	103	120	113 000	258 000	4 000	LRT 9510536
130	35	—	1.1	110	1	101.5	108	123.5	116 000	271 000	3 500	LRT 9511035
130	63	—	1.1	110	0.5	101.5	108	123.5	182 000	514 000	3 500	LRT 9511063
130	30	—	1	110	0.5	105	108	125	106 000	240 000	3 500	LRT 10011030
130	40	—	1	110	1.5	105	108	125	134 000	324 000	3 500	LRT 10011040
135	50	50.5	1.5	110	3	108	108.5	127	183 000	395 000	3 500	LRT 10011050
140	40	—	1.1	115	1	106.5	113	133.5	145 000	329 000	3 500	LRT 10011540
135	50	50.5	1.5	110	—	108	108.5	127	245 000	603 000	1 400	LRTZ 10011050
153	50	50.5	1.5	115	3	113	113.5	145	233 000	414 000	3 500	LRT 10511550
153	50	50.5	1.5	115	—	113	113.5	145	315 000	614 000	1 300	LRTZ 10511550
140	30	—	1	120	1	115	118	135	93 200	239 000	3 500	LRT 11012030
150	40	—	1.1	125	1	116.5	123	143.5	152 000	357 000	3 000	LRT 11012540
150	30	—	1	130	1	125	128	145	96 900	259 000	3 000	LRT 12013030
165	45	—	1.1	135	2	126.5	133	158.5	187 000	435 000	3 000	LRT 12013545
178	60	60.5	1.5	140	2.5	133	138	170	307 000	625 000	3 000	LRT 12514060
178	60	60.5	1.5	140	—	133	138	170	409 000	923 000	1 100	LRTZ 12514060
165	35	—	1.1	145	1	136.5	143	158.5	116 000	340 000	3 000	LRT 13014535
180	50	—	1.5	150	2.5	138	148	172	215 000	540 000	2 500	LRT 13015050
188	60	60.5	1.5	150	2.5	143	148	180	320 000	675 000	2 500	LRT 13515060
188	60	60.5	1.5	150	—	143	148	180	423 000	989 000	1 000	LRTZ 13515060
175	35	—	1.1	155	1	146.5	153	168.5	120 000	363 000	2 500	LRT 14015535
190	50	—	1.5	160	2.5	148	158	182	224 000	580 000	2 500	LRT 14016050
190	40	—	1.1	165	1.5	156.5	163	183.5	168 000	446 000	2 500	LRT 15016540
210	60	—	2	170	3	159	168	201	324 000	712 000	2 500	LRT 15017060

MACHINED TYPE NEEDLE ROLLER BEARINGS

With Inner Ring

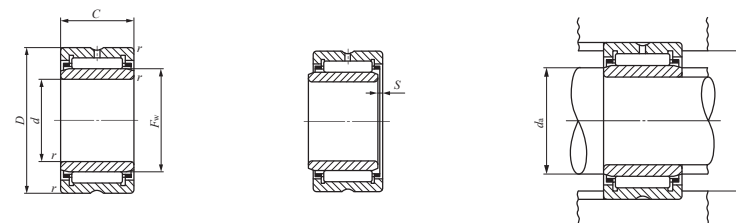

NA49 NA48

Shaft dia. 160 – 340mm

Shaft dia. mm	Identification number						Mass (Ref.) g	d
	NA 49	NA 69	NA 48	TAFI	TRI	GTRI		
160	—	—	NA 4832	—	—	—	3 050	160
	NA 4932	—	—	—	—	—	6 750	160
170	—	—	NA 4834	—	—	—	4 120	170
	NA 4934	—	—	—	—	—	7 110	170
180	—	—	NA 4836	—	—	—	4 340	180
	NA 4936	—	—	—	—	—	10 200	180
190	—	—	NA 4838	—	—	—	5 760	190
	NA 4938	—	—	—	—	—	10 700	190
200	—	—	NA 4840	—	—	—	6 040	200
	NA 4940	—	—	—	—	—	15 400	200
220	—	—	NA 4844	—	—	—	6 570	220
	NA 4944	—	—	—	—	—	16 700	220
240	—	—	NA 4848	—	—	—	10 200	240
	NA 4948	—	—	—	—	—	18 000	240
260	—	—	NA 4852	—	—	—	11 000	260
	NA 4952	—	—	—	—	—	31 100	260
280	—	—	NA 4856	—	—	—	15 800	280
	NA 4956	—	—	—	—	—	33 100	280
300	—	—	NA 4860	—	—	—	22 300	300
	NA 4960	—	—	—	—	—	51 400	300
320	—	—	NA 4864	—	—	—	23 700	320
	NA 4964	—	—	—	—	—	54 400	320
340	—	—	NA 4868	—	—	—	25 000	340
	NA 4968	—	—	—	—	—	57 300	340

Notes⁽¹⁾ Minimum allowable value of chamfer dimension *r*
⁽²⁾ Allowable axial shift amount of inner ring to outer ring
⁽³⁾ Allowable rotational speed applies to oil lubrication. For grease lubrication, a maximum of 60% of this value is allowable.
 Remarks1. The outer ring has an oil groove and an oil hole.
 2. No grease is prepacked. Perform proper lubrication.

Boundary dimensions mm						Standard mounting dimensions mm			Basic dynamic load rating	Basic static load rating	Allowable rotational speed ⁽³⁾	Assembled inner ring
D	C	B	r _{s min} ⁽¹⁾	F _w	S ⁽²⁾	Min. d _a	Max.	D _{a Max.}	C	C ₀	rpm	
200	40	—	1.1	175	1.5	166.5	173	193.5	173 000	474 000	2 500	LRT 16017540
220	60	—	2	180	3	169	178	211	337 000	761 000	1 900	LRT 16018060
215	45	—	1.1	185	1.5	176.5	183	208.5	211 000	567 000	1 900	LRT 17018545
230	60	—	2	190	3	179	188	221	347 000	810 000	1 900	LRT 17019060
225	45	—	1.1	195	1.5	186.5	193	218.5	218 000	602 000	1 900	LRT 18019545
250	69	—	2	205	3	189	203	241	434 000	989 000	1 900	LRT 18020569
240	50	—	1.5	210	1.5	198	208	232	249 000	726 000	1 800	LRT 19021050
260	69	—	2	215	3	199	213	251	440 000	1 020 000	1 700	LRT 19021569
250	50	—	1.5	220	1.5	208	218	242	255 000	766 000	1 600	LRT 20022050
280	80	—	2.1	225	4	211	223	269	518 000	1 120 000	1 600	LRT 20022580
270	50	—	1.5	240	1.5	228	238	262	266 000	833 000	1 500	LRT 22024050
300	80	—	2.1	245	4	231	243	289	536 000	1 200 000	1 400	LRT 22024580
300	60	—	2	265	2	249	262	291	345 000	1 150 000	1 300	LRT 24026560
320	80	—	2.1	265	4	251	262	309	565 000	1 320 000	1 300	LRT 24026580
320	60	—	2	285	2	269	282	311	354 000	1 220 000	1 100	LRT 26028560
360	100	—	2.1	290	4	271	287	349	847 000	1 900 000	1 100	LRT 260290100
350	69	—	2	305	2.5	289	302	341	486 000	1 550 000	950	LRT 28030569
380	100	—	2.1	310	4	291	307	369	877 000	2 040 000	950	LRT 280310100
380	80	—	2.1	330	2.5	311	327	369	610 000	1 900 000	900	LRT 30033080
420	118	—	3	340	4	313	337	407	1 130 000	2 650 000	850	LRT 300340118
400	80	—	2.1	350	2.5	331	347	389	635 000	2 040 000	750	LRT 32035080
440	118	—	3	360	4	333	357	427	1 170 000	2 830 000	750	LRT 320360118
420	80	—	2.1	370	2.5	351	367	409	651 000	2 140 000	700	LRT 34037080
460	118	—	3	380	4	353	377	447	1 220 000	3 020 000	700	LRT 340380118

D
NA
TAFI
TRI
BRI

MACHINED TYPE NEEDLE ROLLER BEARINGS

With Inner Ring

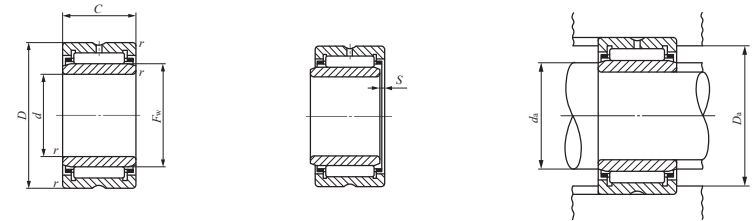

NA49 NA48

Shaft dia. 360 – 440mm

Shaft dia. mm	Identification number						Mass (Ref.) g	d
	NA 49	NA 69	NA 48	TAFI	TRI	GTRI		
360	—	—	NA 4872	—	—	—	26 400	360
	NA 4972	—	—	—	—	—	60 200	360
380	—	—	NA 4876	—	—	—	44 600	380
	NA 4976	—	—	—	—	—	90 300	380
400	NA 4980	—	—	—	—	—	94 400	400
420	NA 4984	—	—	—	—	—	98 500	420
440	NA 4988	—	—	—	—	—	131 000	440

Notes⁽¹⁾ Minimum allowable value of chamfer dimension *r*
⁽²⁾ Allowable axial shift amount of inner ring to outer ring
⁽³⁾ Allowable rotational speed applies to oil lubrication. For grease lubrication, a maximum of 60% of this value is allowable.
 Remarks1. The outer ring has an oil groove and an oil hole.
 2. No grease is prepacked. Perform proper lubrication.

Boundary dimensions mm							Standard mounting dimensions mm			Basic dynamic load rating	Basic static load rating	Allowable rotational speed ⁽³⁾	Assembled inner ring
D	C	B	r _s min ⁽¹⁾	F _w	S ⁽²⁾	Min. d _a	Max. d _a	D _a Max.	C	C ₀	rpm		
440	80	—	2.1	390	2.5	371	387	429	680 000	2 320 000	650	LRT 36039080	
480	118	—	3	400	4	373	397	467	1 260 000	3 200 000	600	LRT 360400118	
480	100	—	2.1	415	3	391	412	469	951 000	2 860 000	600	LRT 380415100	
520	140	—	4	430	5	396	427	504	1 540 000	4 030 000	500	LRT 380430140	
540	140	—	4	450	5	416	447	524	1 590 000	4 270 000	500	LRT 400450140	
560	140	—	4	470	5	436	467	544	1 640 000	4 510 000	500	LRT 420470140	
600	160	—	4	490	5	456	487	584	1 910 000	5 140 000	400	LRT 440490160	

D

NA
TAFI
TRI
BRI

MACHINED TYPE NEEDLE ROLLER BEARINGS

Without Inner Ring, Inch Series

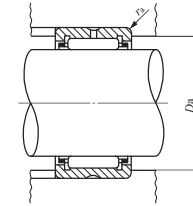
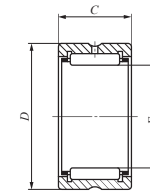

BR

Shaft dia. 15.875 – 47.625mm

Shaft dia. mm (inch)	Identification number	Mass (Ref.) g	Boundary dimensions mm(inch)			Standard mounting dimensions mm	
			F_w	D	C	D_a Max.	$r_{as\ max}^{(1)}$
15.875 (5/8)	BR 101812	49	15.875 (5/8)	28.575 (1 1/8)	19.050 (3/4)	24.5	0.6
19.050 (3/4)	BR 122012	56	19.050 (3/4)	31.750 (1 1/4)	19.050 (3/4)	26.5	1
	BR 122016	75	19.050 (3/4)	31.750 (1 1/4)	25.400 (1)	26.5	1
22.225 (7/8)	BR 142212	63	22.225 (7/8)	34.925 (1 3/8)	19.050 (3/4)	29.7	1
	BR 142216	84.5	22.225 (7/8)	34.925 (1 3/8)	25.400 (1)	29.7	1
25.400 (1)	BR 162412	69	25.400 (1)	38.100 (1 1/2)	19.050 (3/4)	32.9	1
	BR 162416	92.5	25.400 (1)	38.100 (1 1/2)	25.400 (1)	32.9	1
28.575 (1 1/8)	BR 182616	102	28.575 (1 1/8)	41.275 (1 5/8)	25.400 (1)	36	1
	BR 182620	128	28.575 (1 1/8)	41.275 (1 5/8)	31.750 (1 1/4)	36	1
31.750 (1 1/4)	BR 202816	110	31.750 (1 1/4)	44.450 (1 3/4)	25.400 (1)	39.2	1
	BR 202820	138	31.750 (1 1/4)	44.450 (1 3/4)	31.750 (1 1/4)	39.2	1
34.925 (1 3/8)	BR 223016	119	34.925 (1 3/8)	47.625 (1 7/8)	25.400 (1)	42.4	1
	BR 223020	149	34.925 (1 3/8)	47.625 (1 7/8)	31.750 (1 1/4)	42.4	1
38.100 (1 1/2)	BR 243316	149	38.100 (1 1/2)	52.388 (2 1/16)	25.400 (1)	45.1	1.5
	BR 243320	187	38.100 (1 1/2)	52.388 (2 1/16)	31.750 (1 1/4)	45.1	1.5
41.275 (1 5/8)	BR 263516	158	41.275 (1 5/8)	55.562 (2 3/16)	25.400 (1)	48.3	1.5
	BR 263520	199	41.275 (1 5/8)	55.562 (2 3/16)	31.750 (1 1/4)	48.3	1.5
44.450 (1 3/4)	BR 283716	170	44.450 (1 3/4)	58.738 (2 3/16)	25.400 (1)	51.5	1.5
	BR 283720	215	44.450 (1 3/4)	58.738 (2 3/16)	31.750 (1 1/4)	51.5	1.5
	BR 283820	250	44.450 (1 3/4)	60.325 (2 3/8)	31.750 (1 1/4)	53.1	1.5
47.625 (1 7/8)	BR 303920	225	47.625 (1 7/8)	61.912 (2 7/16)	31.750 (1 1/4)	54.7	1.5

Notes⁽¹⁾ Maximum permissible corner radius of the housing
⁽²⁾ Allowable rotational speed applies to oil lubrication. For grease lubrication, a maximum of 60% of this value is allowable.
 Remarks1. The outer ring has an oil groove and an oil hole.
 2. No grease is prepacked. Perform proper lubrication.

Basic dynamic load rating C N	Basic static load rating C_0 N	Allowable rotational speed ⁽²⁾ rpm
18 900	19 700	25 000
21 700	24 400	20 000
27 600	33 100	20 000
23 000	27 100	18 000
29 100	36 800	18 000
25 300	31 900	16 000
32 100	43 300	16 000
34 900	49 900	14 000
43 200	65 600	14 000
36 000	53 500	13 000
44 600	70 300	13 000
38 500	60 000	11 000
47 700	78 900	11 000
43 700	66 900	11 000
54 200	88 200	11 000
44 800	70 900	9 500
55 600	93 400	9 500
47 500	78 200	9 000
58 900	103 000	9 000
58 900	103 000	9 000
60 100	108 000	8 500

D
 NA
 TAFI
 TRI
 BRI

MACHINED TYPE NEEDLE ROLLER BEARINGS

Without Inner Ring, Inch Series

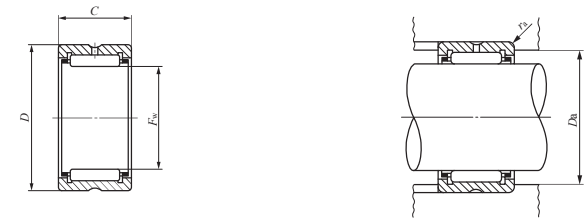

BR

Shaft dia. 50.800 – 101.600mm

Shaft dia. mm (inch)	Identification number	Mass (Ref.) g	Boundary dimensions mm(inch)			Standard mounting dimensions mm	
			F_w	D	C	D_a Max.	$r_{as\ max}^{(1)}$
50.800 (2)	BR 324116	190	50.800 (2)	65.088 (2 5/16)	25.400 (1)	57.8	1.5
	BR 324120	240	50.800 (2)	65.088 (2 5/16)	31.750 (1 1/4)	57.8	1.5
57.150 (2 1/4)	BR 364824	435	57.150 (2 1/4)	76.200 (3)	38.100 (1 1/2)	69	1.5
	BR 364828	510	57.150 (2 1/4)	76.200 (3)	44.450 (1 3/4)	69	1.5
63.500 (2 1/2)	BR 405224	475	63.500 (2 1/2)	82.550 (3 1/4)	38.100 (1 1/2)	74.3	2
	BR 405228	555	63.500 (2 1/2)	82.550 (3 1/4)	44.450 (1 3/4)	74.3	2
69.850 (2 3/4)	BR 445624	510	69.850 (2 3/4)	88.900 (3 1/2)	38.100 (1 1/2)	80.7	2
	BR 445628	600	69.850 (2 3/4)	88.900 (3 1/2)	44.450 (1 3/4)	80.7	2
76.200 (3)	BR 486024	555	76.200 (3)	95.250 (3 3/4)	38.100 (1 1/2)	87	2
	BR 486028	650	76.200 (3)	95.250 (3 3/4)	44.450 (1 3/4)	87	2
82.550 (3 1/4)	BR 526828	990	82.550 (3 1/4)	107.950 (4 1/4)	44.450 (1 3/4)	99.7	2
	BR 526832	1 140	82.550 (3 1/4)	107.950 (4 1/4)	50.800 (2)	99.7	2
88.900 (3 1/2)	BR 567232	1 220	88.900 (3 1/2)	114.300 (4 1/2)	50.800 (2)	106.1	2
95.250 (3 3/4)	BR 607632	1 290	95.250 (3 3/4)	120.650 (4 3/4)	50.800 (2)	111.4	2.5
101.600 (4)	BR 648032	1 370	101.600 (4)	127.000 (5)	50.800 (2)	117.8	2.5

Notes⁽¹⁾ Maximum permissible corner radius of the housing
⁽²⁾ Allowable rotational speed applies to oil lubrication. For grease lubrication, a maximum of 60% of this value is allowable.

Remarks1. In bearings with a roller set bore diameter F_w of 69.850 mm or less, the outer ring has an oil groove and an oil hole. In others, the outer ring has an oil groove and two oil holes.
 2. No grease is prepacked. Perform proper lubrication.

Basic dynamic load rating C N	Basic static load rating C_0 N	Allowable rotational speed ⁽²⁾ rpm
51 000	89 400	8 000
63 200	118 000	8 000
90 300	158 000	7 000
105 000	191 000	7 000
94 600	174 000	6 500
110 000	210 000	6 500
98 700	189 000	5 500
114 000	228 000	5 500
105 000	211 000	5 500
122 000	255 000	5 500
141 000	259 000	5 000
154 000	290 000	5 000
162 000	316 000	4 500
169 000	342 000	4 000
176 000	368 000	4 000

D

NA
TAFI
TRI
BRI

MACHINED TYPE NEEDLE ROLLER BEARINGS

With Inner Ring, Inch Series

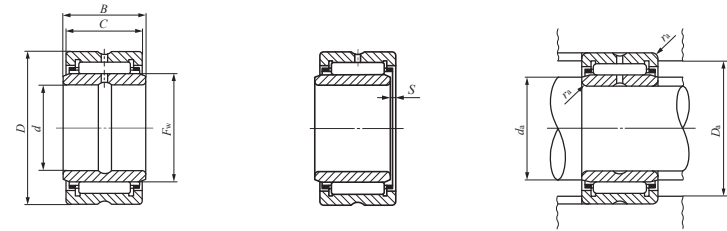

BRI

Shaft dia. 9.525 – 41.275mm

Shaft dia. mm (inch)	Identification number	Mass (Ref.) g	Boundary dimensions mm(inch)						⁽¹⁾ S
			d	D	C	B	F _w		
9.525 (³ / ₈)	BRI 61812	67.5	9.525 (³ / ₈)	28.575 (1 ¹ / ₈)	19.050 (³ / ₄)	19.300	15.875 (⁵ / ₈)	0.3	
		79.5	12.700 (¹ / ₂)	31.750 (1 ¹ / ₄)	19.050 (³ / ₄)	19.300	19.050 (³ / ₄)	0.3	
12.700 (¹ / ₂)	BRI 82012 BRI 82016	106	12.700 (¹ / ₂)	31.750 (1 ¹ / ₄)	25.400 (1)	25.650	19.050 (³ / ₄)	0.5	
		91	15.875 (⁵ / ₈)	34.925 (1 ³ / ₈)	19.050 (³ / ₄)	19.300	22.225 (⁷ / ₈)	0.3	
15.875 (⁵ / ₈)	BRI 102212 BRI 102216	122	15.875 (⁵ / ₈)	34.925 (1 ³ / ₈)	25.400 (1)	25.650	22.225 (⁷ / ₈)	0.5	
		102	19.050 (³ / ₄)	38.100 (1 ¹ / ₂)	19.050 (³ / ₄)	19.300	25.400 (1)	0.3	
19.050 (³ / ₄)	BRI 122412 BRI 122416	136	19.050 (³ / ₄)	38.100 (1 ¹ / ₂)	25.400 (1)	25.650	25.400 (1)	0.5	
		152	22.225 (⁷ / ₈)	41.275 (1 ⁵ / ₈)	25.400 (1)	25.650	28.575 (1 ¹ / ₈)	0.5	
22.225 (⁷ / ₈)	BRI 142616 BRI 142620	190	22.225 (⁷ / ₈)	41.275 (1 ⁵ / ₈)	31.750 (1 ¹ / ₄)	32.000	28.575 (1 ¹ / ₈)	0.5	
		166	25.400 (1)	44.450 (1 ³ / ₄)	25.400 (1)	25.650	31.750 (1 ¹ / ₄)	0.5	
25.400 (1)	BRI 162816 BRI 162820	210	25.400 (1)	44.450 (1 ³ / ₄)	31.750 (1 ¹ / ₄)	32.000	31.750 (1 ¹ / ₄)	0.5	
		182	28.575 (1 ¹ / ₈)	47.625 (1 ⁷ / ₈)	25.400 (1)	25.650	34.925 (1 ³ / ₈)	0.5	
28.575 (1 ¹ / ₈)	BRI 183016 BRI 183020	225	28.575 (1 ¹ / ₈)	47.625 (1 ⁷ / ₈)	31.750 (1 ¹ / ₄)	32.000	34.925 (1 ³ / ₈)	0.5	
		220	31.750 (1 ¹ / ₄)	52.388 (2 ¹ / ₁₆)	25.400 (1)	25.650	38.100 (1 ¹ / ₂)	0.5	
31.750 (1 ¹ / ₄)	BRI 203316 BRI 203320	275	31.750 (1 ¹ / ₄)	52.388 (2 ¹ / ₁₆)	31.750 (1 ¹ / ₄)	32.000	38.100 (1 ¹ / ₂)	0.5	
		235	34.925 (1 ³ / ₈)	55.562 (2 ³ / ₁₆)	25.400 (1)	25.650	41.275 (1 ⁵ / ₈)	0.5	
34.925 (1 ³ / ₈)	BRI 223516 BRI 223520	295	34.925 (1 ³ / ₈)	55.562 (2 ³ / ₁₆)	31.750 (1 ¹ / ₄)	32.000	41.275 (1 ⁵ / ₈)	0.5	
		250	38.100 (1 ¹ / ₂)	58.738 (2 ³ / ₁₆)	25.400 (1)	25.650	44.450 (1 ³ / ₄)	0.5	
38.100 (1 ¹ / ₂)	BRI 243716 BRI 243720 BRI 243820 BRI 243920	315	38.100 (1 ¹ / ₂)	58.738 (2 ³ / ₁₆)	31.750 (1 ¹ / ₄)	32.000	44.450 (1 ³ / ₄)	0.5	
		350	38.100 (1 ¹ / ₂)	60.325 (2 ³ / ₈)	31.750 (1 ¹ / ₄)	32.000	44.450 (1 ³ / ₄)	0.5	
		380	38.100 (1 ¹ / ₂)	61.912 (2 ⁷ / ₁₆)	31.750 (1 ¹ / ₄)	32.000	47.625 (1 ⁷ / ₈)	0.5	
		325	41.275 (1 ⁵ / ₈)	65.088 (2 ⁹ / ₁₆)	25.400 (1)	25.650	50.800 (2)	0.5	
41.275 (1 ⁵ / ₈)	BRI 264116 BRI 264120	410	41.275 (1 ⁵ / ₈)	65.088 (2 ⁹ / ₁₆)	31.750 (1 ¹ / ₄)	32.000	50.800 (2)	0.5	

Notes⁽¹⁾ Allowable axial shift amount of inner ring to outer ring
⁽²⁾ Maximum permissible corner radius of the shaft or housing
⁽³⁾ Allowable rotational speed applies to oil lubrication. For grease lubrication, a maximum of 60% of this value is allowable.
 Remarks1. The inner ring and the outer ring each have an oil groove and an oil hole.
 2. No grease is prepacked. Perform proper lubrication.

Standard mounting dimensions mm				Basic dynamic load rating C N	Basic static load rating C ₀ N	Allowable rotational speed ⁽³⁾ rpm	Assembled inner ring
Min.	Max.	Max.	r _{as max} ⁽²⁾				
14	14.5	24.5	0.6	18 900	19 700	25 000	LRB 61012
17.5	18	26.5	1	21 700	24 400	20 000	LRB 81212
17.5	18	26.5	1	27 600	33 100	20 000	LRB 81216
21	21.2	29.7	1	23 000	27 100	18 000	LRB 101412
21	21.2	29.7	1	29 100	36 800	18 000	LRB 101416
24	24.4	32.9	1	25 300	31 900	16 000	LRB 121612
24	24.4	32.9	1	32 100	43 300	16 000	LRB 121616
27	27.5	36	1	34 900	49 900	14 000	LRB 141816
27	27.5	36	1	43 200	65 600	14 000	LRB 141820
30.5	30.7	39.2	1	36 000	53 500	13 000	LRB 162016
30.5	30.7	39.2	1	44 600	70 300	13 000	LRB 162020
33.5	33.9	42.4	1	38 500	60 000	11 000	LRB 182216
33.5	33.9	42.4	1	47 700	78 900	11 000	LRB 182220
37	37.1	45.1	1.5	43 700	66 900	11 000	LRB 202416
37	37.1	45.1	1.5	54 200	88 200	11 000	LRB 202420
40.2	40.2	48.3	1.5	44 800	70 900	9 500	LRB 222616
40.2	40.2	48.3	1.5	55 600	93 400	9 500	LRB 222620
43.3	43.4	51.5	1.5	47 500	78 200	9 000	LRB 242816
43.3	43.4	51.5	1.5	58 900	103 000	9 000	LRB 242820
43.3	43.4	53.1	1.5	58 900	103 000	9 000	LRB 242820
43.3	43.4	54.7	1.5	60 100	108 000	8 500	LRB 243020
48	49	57.8	1.5	51 000	89 400	8 000	LRB 263216
48	49	57.8	1.5	63 200	118 000	8 000	LRB 263220

D

NA
TAFI
TRI
BRI

MACHINED TYPE NEEDLE ROLLER BEARINGS

With Inner Ring, Inch Series

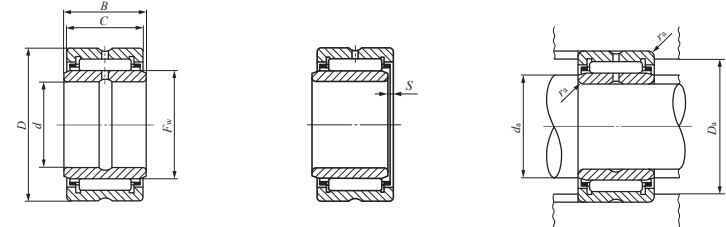

BRI

Shaft dia. 44.450 – 88.900mm

Shaft dia. mm (inch)	Identification number	Mass (Ref.) g	Boundary dimensions mm(inch)					
			<i>d</i>	<i>D</i>	<i>C</i>	<i>B</i>	<i>F_w</i>	<i>S</i> ⁽¹⁾
44.450 (1 3/4)	BRI 284824	735	44.450 (1 3/4)	76.200 (3)	38.100 (1 1/2)	38.350	57.150 (2 1/4)	1
	BRI 284828	855	44.450 (1 3/4)	76.200 (3)	44.450 (1 3/4)	44.700	57.150 (2 1/4)	1
50.800 (2)	BRI 325224	810	50.800 (2)	82.550 (3 1/4)	38.100 (1 1/2)	38.350	63.500 (2 1/2)	1
	BRI 325228	945	50.800 (2)	82.550 (3 1/4)	44.450 (1 3/4)	44.700	63.500 (2 1/2)	1
57.150 (2 1/4)	BRI 365624	885	57.150 (2 1/4)	88.900 (3 1/2)	38.100 (1 1/2)	38.350	69.850 (2 3/4)	1
	BRI 365628	1 040	57.150 (2 1/4)	88.900 (3 1/2)	44.450 (1 3/4)	44.700	69.850 (2 3/4)	1
63.500 (2 1/2)	BRI 406024	965	63.500 (2 1/2)	95.250 (3 3/4)	38.100 (1 1/2)	38.350	76.200 (3)	1
	BRI 406028	1 130	63.500 (2 1/2)	95.250 (3 3/4)	44.450 (1 3/4)	44.700	76.200 (3)	1
69.850 (2 3/4)	BRI 446828	1 520	69.850 (2 3/4)	107.950 (4 1/4)	44.450 (1 3/4)	44.700	82.550 (3 1/4)	1.5
	BRI 446832	1 740	69.850 (2 3/4)	107.950 (4 1/4)	50.800 (2)	51.050	82.550 (3 1/4)	3
76.200 (3)	BRI 487232	1 860	76.200 (3)	114.300 (4 1/2)	50.800 (2)	51.050	88.900 (3 1/2)	3
82.550 (3 1/4)	BRI 527632	1 980	82.550 (3 1/4)	120.650 (4 3/4)	50.800 (2)	51.050	95.250 (3 3/4)	3
88.900 (3 1/2)	BRI 568032	2 120	88.900 (3 1/2)	127.000 (5)	50.800 (2)	51.050	101.600 (4)	3

Notes⁽¹⁾ Allowable axial shift amount of inner ring to outer ring
⁽²⁾ Maximum permissible corner radius of the shaft or housing
⁽³⁾ Allowable rotational speed applies to oil lubrication. For grease lubrication, a maximum of 60% of this value is allowable.
 Remarks1. In bearings with a bearing bore diameter, *d*, of 57.150 mm or less, the outer ring has an oil groove and an oil hole. In bearings with a bearing bore diameter, *d*, of 76.200 mm or less, the inner ring has an oil groove and an oil hole. In others, the inner ring and the outer ring each have an oil groove and two oil holes.
 2. No grease is prepacked. Perform proper lubrication.

Standard mounting dimensions mm				Basic dynamic load rating <i>C</i> N	Basic static load rating <i>C₀</i> N	Allowable rotational speed ⁽³⁾ rpm	Assembled inner ring
<i>d_a</i> Min.	<i>d_a</i> Max.	<i>D_a</i> Max.	<i>r_{as max}</i> ⁽²⁾				
52.5	55	69	1.5	90 300	158 000	7 000	LRB 283624
52.5	55	69	1.5	105 000	191 000	7 000	LRB 283628
58	61	74.3	2	94 600	174 000	6 500	LRB 324024
58	61	74.3	2	110 000	210 000	6 500	LRB 324028
65	67	80.7	2	98 700	189 000	5 500	LRB 364424
65	67	80.7	2	114 000	228 000	5 500	LRB 364428
71	73	87	2	105 000	211 000	5 500	LRB 404824
71	73	87	2	122 000	255 000	5 500	LRB 404828
77	79	99.7	2	141 000	259 000	5 000	LRB 445228
77	79	99.7	2	154 000	290 000	5 000	LRB 445232
83.5	86	106.1	2	162 000	316 000	4 500	LRB 485632
91	93	111.4	2.5	169 000	342 000	4 000	LRB 526032
97	99	117.8	2.5	176 000	368 000	4 000	LRB 566432

D
NA
TAFI
TRI
BRI

MACHINED TYPE NEEDLE ROLLER BEARINGS

Without Inner Ring, Inch Series

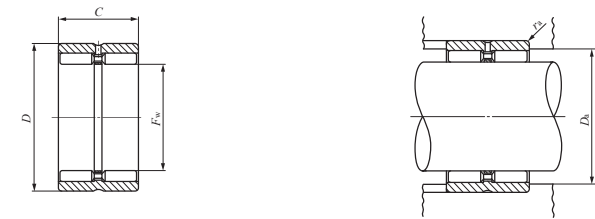

GBR

Shaft dia. 15.875 – 50.800mm

Shaft dia. mm (inch)	Identification number	Mass (Ref.) g	Boundary dimensions mm(inch)			Standard mounting dimensions mm	
			F_w	D	C	D_a Max.	$r_{as\ max}^{(1)}$
15.875 (5/8)	GBR 101812	55.5	15.875 (5/8)	28.575 (1 1/8)	19.050 (3/4)	24.5	0.6
19.050 (3/4)	GBR 122012	63	19.050 (3/4)	31.750 (1 1/4)	19.050 (3/4)	27	0.6
22.225 (7/8)	GBR 142212	71	22.225 (7/8)	34.925 (1 3/8)	19.050 (3/4)	30	0.6
	GBR 142216	95.5	22.225 (7/8)	34.925 (1 3/8)	25.400 (1)	30	0.6
25.400 (1)	GBR 162412	79	25.400 (1)	38.100 (1 1/2)	19.050 (3/4)	33.3	0.6
	GBR 162416	106	25.400 (1)	38.100 (1 1/2)	25.400 (1)	33.3	0.6
28.575 (1 1/8)	GBR 182616	117	28.575 (1 1/8)	41.275 (1 5/8)	25.400 (1)	36.3	0.6
31.750 (1 1/4)	GBR 202816	128	31.750 (1 1/4)	44.450 (1 3/4)	25.400 (1)	39.6	0.6
34.925 (1 3/8)	GBR 223016	137	34.925 (1 3/8)	47.625 (1 7/8)	25.400 (1)	42.8	0.6
38.100 (1 1/2)	GBR 243316	168	38.100 (1 1/2)	52.388 (2 1/16)	25.400 (1)	47.3	0.6
	GBR 243320	205	38.100 (1 1/2)	52.388 (2 1/16)	31.750 (1 1/4)	47.3	0.6
41.275 (1 5/8)	GBR 263516	180	41.275 (1 5/8)	55.562 (2 3/16)	25.400 (1)	50.5	0.6
	GBR 263520	220	41.275 (1 5/8)	55.562 (2 3/16)	31.750 (1 1/4)	50.5	0.6
44.450 (1 3/4)	GBR 283720	235	44.450 (1 3/4)	58.738 (2 5/16)	31.750 (1 1/4)	53.7	0.6
	GBR 283820	275	44.450 (1 3/4)	60.325 (2 3/8)	31.750 (1 1/4)	55.3	0.6
47.625 (1 7/8)	GBR 303920	250	47.625 (1 7/8)	61.912 (2 1/16)	31.750 (1 1/4)	56.2	1
50.800 (2)	GBR 324116	215	50.800 (2)	65.088 (2 9/16)	25.400 (1)	59.2	1
	GBR 324120	265	50.800 (2)	65.088 (2 9/16)	31.750 (1 1/4)	59.2	1

Notes⁽¹⁾ Maximum permissible corner radius of the housing
⁽²⁾ Allowable rotational speed applies to oil lubrication. For grease lubrication, a maximum of 60% of this value is allowable.

Remarks1. The outer ring has an oil groove and an oil hole.
 2. No grease is prepacked. Perform proper lubrication.

Basic dynamic load rating C N	Basic static load rating C_0 N	Allowable rotational speed ⁽²⁾ rpm
23 500	28 500	9 500
26 400	34 500	8 000
28 600	40 100	7 000
38 300	58 300	7 000
31 000	46 100	6 000
41 400	67 100	6 000
43 900	75 300	5 500
46 600	83 900	4 500
49 500	91 800	4 500
54 200	97 700	4 000
64 100	121 000	4 000
56 600	105 000	3 500
67 000	130 000	3 500
69 700	141 000	3 500
69 700	141 000	3 500
72 400	150 000	3 000
63 100	130 000	3 000
74 600	162 000	3 000

D

NA
TAFI
TRI
BRI

MACHINED TYPE NEEDLE ROLLER BEARINGS

Without Inner Ring, Inch Series



GBR

Shaft dia. 57.150 – 107.950mm

Shaft dia. mm (inch)	Identification number	Mass (Ref.) g	Boundary dimensions mm(inch)			Standard mounting dimensions mm	
			F_w	D	C	D_a Max.	$r_{as\ max}^{(1)}$
57.150 (2 1/4)	GBR 364824	490	57.150 (2 1/4)	76.200 (3)	38.100 (1 1/2)	69.2	1.5
	GBR 364828	580	57.150 (2 1/4)	76.200 (3)	44.450 (1 3/4)	69.2	1.5
63.500 (2 1/2)	GBR 405224	535	63.500 (2 1/2)	82.550 (3 1/4)	38.100 (1 1/2)	75.7	1.5
	GBR 405228	635	63.500 (2 1/2)	82.550 (3 1/4)	44.450 (1 3/4)	75.7	1.5
69.850 (2 3/4)	GBR 445624	585	69.850 (2 3/4)	88.900 (3 1/2)	38.100 (1 1/2)	82	1.5
	GBR 445628	690	69.850 (2 3/4)	88.900 (3 1/2)	44.450 (1 3/4)	82	1.5
76.200 (3)	GBR 486024	630	76.200 (3)	95.250 (3 3/4)	38.100 (1 1/2)	88	1.5
	GBR 486028	745	76.200 (3)	95.250 (3 3/4)	44.450 (1 3/4)	88	1.5
82.550 (3 1/4)	GBR 526828	1 100	82.550 (3 1/4)	107.950 (4 1/4)	44.450 (1 3/4)	99.9	1.5
	GBR 526832	1 240	82.550 (3 1/4)	107.950 (4 1/4)	50.800 (2)	99.9	1.5
88.900 (3 1/2)	GBR 567232	1 330	88.900 (3 1/2)	114.300 (4 1/2)	50.800 (2)	106.3	1.5
95.250 (3 3/4)	GBR 607632	1 420	95.250 (3 3/4)	120.650 (4 3/4)	50.800 (2)	112.6	1.5
101.600 (4)	GBR 648032	1 500	101.600 (4)	127.000 (5)	50.800 (2)	119	1.5
107.950 (4 1/4)	GBR 688432	1 580	107.950 (4 1/4)	133.350 (5 1/4)	50.800 (2)	125.3	1.5

Notes⁽¹⁾ Maximum permissible corner radius of the housing
⁽²⁾ Allowable rotational speed applies to oil lubrication. For grease lubrication, a maximum of 60% of this value is allowable.
 Remarks1. The outer ring has an oil groove and an oil hole.
 2. No grease is prepacked. Perform proper lubrication.

Basic dynamic load rating C	Basic static load rating C_0	Allowable rotational speed ⁽²⁾
N	N	rpm
113 000	224 000	2 500
133 000	276 000	2 500
120 000	248 000	2 500
141 000	306 000	2 500
125 000	273 000	2 000
147 000	336 000	2 000
131 000	298 000	2 000
154 000	368 000	2 000
193 000	396 000	1 800
214 000	452 000	1 800
221 000	488 000	1 700
228 000	522 000	1 600
237 000	556 000	1 500
242 000	590 000	1 400

D
 NA
 TAFI
 TRI
 BRI

MACHINED TYPE NEEDLE ROLLER BEARINGS

With Inner Ring, Inch Series

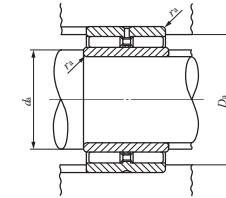
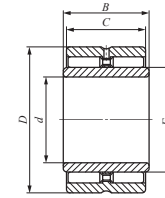

GBRI

Shaft dia. 9.525 – 41.275mm

Shaft dia. mm (inch)	Identification number	Mass (Ref.) g	Boundary dimensions mm(inch)				
			d	D	C	B	F _w
9.525 (3/8)	GBRI 61812	74	9.525 (3/8)	28.575 (1 1/8)	19.050 (3/4)	19.300	15.875 (5/8)
12.700 (1/2)	GBRI 82012	86.5	12.700 (1/2)	31.750 (1 1/4)	19.050 (3/4)	19.300	19.050 (3/4)
15.875 (5/8)	GBRI 102212	99	15.875 (5/8)	34.925 (1 3/8)	19.050 (3/4)	19.300	22.225 (7/8)
	GBRI 102216	133	15.875 (5/8)	34.925 (1 3/8)	25.400 (1)	25.650	22.225 (7/8)
19.050 (3/4)	GBRI 122412	112	19.050 (3/4)	38.100 (1 1/2)	19.050 (3/4)	19.300	25.400 (1)
	GBRI 122416	150	19.050 (3/4)	38.100 (1 1/2)	25.400 (1)	25.650	25.400 (1)
22.225 (7/8)	GBRI 142616	167	22.225 (7/8)	41.275 (1 5/8)	25.400 (1)	25.650	28.575 (1 1/8)
25.400 (1)	GBRI 162816	184	25.400 (1)	44.450 (1 3/4)	25.400 (1)	25.650	31.750 (1 1/4)
28.575 (1 1/8)	GBRI 183016	200	28.575 (1 1/8)	47.625 (1 7/8)	25.400 (1)	25.650	34.925 (1 3/8)
	GBRI 203316	235	31.750 (1 1/4)	52.388 (2 1/16)	25.400 (1)	25.650	38.100 (1 1/2)
31.750 (1 1/4)	GBRI 203320	291	31.750 (1 1/4)	52.388 (2 1/16)	31.750 (1 1/4)	32.000	38.100 (1 1/2)
	GBRI 223516	255	34.925 (1 3/8)	55.562 (2 3/16)	25.400 (1)	25.650	41.275 (1 5/8)
34.925 (1 3/8)	GBRI 223520	316	34.925 (1 3/8)	55.562 (2 3/16)	31.750 (1 1/4)	32.000	41.275 (1 5/8)
	GBRI 243720	335	38.100 (1 1/2)	58.738 (2 5/16)	31.750 (1 1/4)	32.000	44.450 (1 3/4)
38.100 (1 1/2)	GBRI 243820	375	38.100 (1 1/2)	60.325 (2 3/8)	31.750 (1 1/4)	32.000	44.450 (1 3/4)
	GBRI 243920	410	38.100 (1 1/2)	61.912 (2 7/16)	31.750 (1 1/4)	32.000	47.625 (1 7/8)
41.275 (1 5/8)	GBRI 264116	350	41.275 (1 5/8)	65.088 (2 9/16)	25.400 (1)	25.650	50.800 (2)
	GBRI 264120	435	41.275 (1 5/8)	65.088 (2 9/16)	31.750 (1 1/4)	32.000	50.800 (2)

Notes⁽¹⁾ Maximum permissible corner radius of the shaft or housing
⁽²⁾ Allowable rotational speed applies to oil lubrication. For grease lubrication, a maximum of 60% of this value is allowable.
 Remarks1. The outer ring has an oil groove and an oil hole.
 2. No grease is prepacked. Perform proper lubrication.

Standard mounting dimensions mm				Basic dynamic load rating C	Basic static load rating C ₀	Allowable rotational speed ⁽²⁾ rpm	Assembled inner ring
d _a Min.	d _a Max.	D _a Max.	r _{as max} ⁽¹⁾				
14	14.5	24.5	0.6	23 500	28 500	9 500	LRBZ 61012
17.5	18	27	0.6	26 400	34 500	8 000	LRBZ 81212
21	21.2	30	0.6	28 600	40 100	7 000	LRBZ 101412
21	21.2	30	0.6	38 300	58 300	7 000	LRBZ 101416
24	24.4	33.3	0.6	31 000	46 100	6 000	LRBZ 121612
24	24.4	33.3	0.6	41 400	67 100	6 000	LRBZ 121616
27	27.5	36.3	0.6	43 900	75 300	5 500	LRBZ 141816
30.5	30.7	39.6	0.6	46 600	83 900	4 500	LRBZ 162016
33.5	33.9	42.8	0.6	49 500	91 800	4 500	LRBZ 182216
37	37.1	47.3	0.6	54 200	97 700	4 000	LRBZ 202416
37	37.1	47.3	0.6	64 100	121 000	4 000	LRBZ 202420
40.2	40.2	50.5	0.6	56 600	105 000	3 500	LRBZ 222616
40.2	40.2	50.5	0.6	67 000	130 000	3 500	LRBZ 222620
43.3	43.4	53.7	0.6	69 700	141 000	3 500	LRBZ 242820
43.3	43.4	55.3	0.6	69 700	141 000	3 500	LRBZ 242820
43.3	45	56.2	1	72 400	150 000	3 000	LRBZ 243020
48	49	59.2	1	63 100	130 000	3 000	LRBZ 263216
48	49	59.2	1	74 600	162 000	3 000	LRBZ 263220

D
NA
TAFI
TRI
BRI

MACHINED TYPE NEEDLE ROLLER BEARINGS

With Inner Ring, Inch Series

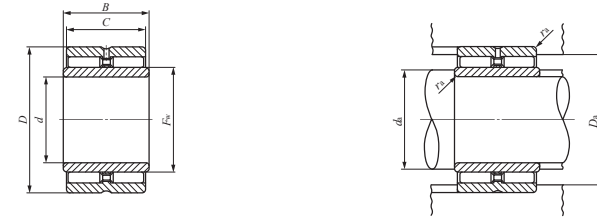

GBRI

Shaft dia. 44.450 – 95.250mm

Shaft dia. mm (inch)	Identification number	Mass (Ref.) g	Boundary dimensions mm(inch)				
			d	D	C	B	F _w
44.450 (1 3/4)	GBRI 284824	790	44.450 (1 3/4)	76.200 (3)	38.100 (1 1/2)	38.350	57.150 (2 1/4)
	GBRI 284828	925	44.450 (1 3/4)	76.200 (3)	44.450 (1 3/4)	44.700	57.150 (2 1/4)
50.800 (2)	GBRI 325224	870	50.800 (2)	82.550 (3 1/4)	38.100 (1 1/2)	38.350	63.500 (2 1/2)
	GBRI 325228	1 030	50.800 (2)	82.550 (3 1/4)	44.450 (1 3/4)	44.700	63.500 (2 1/2)
57.150 (2 1/4)	GBRI 365624	955	57.150 (2 1/4)	88.900 (3 1/2)	38.100 (1 1/2)	38.350	69.850 (2 3/4)
	GBRI 365628	1 130	57.150 (2 1/4)	88.900 (3 1/2)	44.450 (1 3/4)	44.700	69.850 (2 3/4)
63.500 (2 1/2)	GBRI 406024	1 040	63.500 (2 1/2)	95.250 (3 3/4)	38.100 (1 1/2)	38.350	76.200 (3)
	GBRI 406028	1 230	63.500 (2 1/2)	95.250 (3 3/4)	44.450 (1 3/4)	44.700	76.200 (3)
69.850 (2 3/4)	GBRI 446828	1 630	69.850 (2 3/4)	107.950 (4 1/4)	44.450 (1 3/4)	44.700	82.550 (3 1/4)
	GBRI 446832	1 840	69.850 (2 3/4)	107.950 (4 1/4)	50.800 (2)	51.050	82.550 (3 1/4)
76.200 (3)	GBRI 487232	1 970	76.200 (3)	114.300 (4 1/2)	50.800 (2)	51.050	88.900 (3 1/2)
82.550 (3 1/4)	GBRI 527632	2 110	82.550 (3 1/4)	120.650 (4 3/4)	50.800 (2)	51.050	95.250 (3 3/4)
88.900 (3 1/2)	GBRI 568032	2 250	88.900 (3 1/2)	127.000 (5)	50.800 (2)	51.050	101.600 (4)
95.250 (3 3/4)	GBRI 608432	2 380	95.250 (3 3/4)	133.350 (5 1/4)	50.800 (2)	51.050	107.950 (4 1/4)

Notes⁽¹⁾ Maximum permissible corner radius of the shaft or housing
⁽²⁾ Allowable rotational speed applies to oil lubrication. For grease lubrication, a maximum of 60% of this value is allowable.
 Remarks1. The outer ring has an oil groove and an oil hole.
 2. No grease is prepacked. Perform proper lubrication.

Standard mounting dimensions mm				Basic dynamic load rating C	Basic static load rating C ₀	Allowable rotational speed ⁽²⁾ rpm	Assembled inner ring
Min.	Max.	Max.	r _{as max} ⁽¹⁾				
52.5	55	69.2	1.5	113 000	224 000	2 500	LRBZ 283624
52.5	55	69.2	1.5	133 000	276 000	2 500	LRBZ 283628
58	61	75.7	1.5	120 000	248 000	2 500	LRBZ 324024
58	61	75.7	1.5	141 000	306 000	2 500	LRBZ 324028
65	67	82	1.5	125 000	273 000	2 000	LRBZ 364424
65	67	82	1.5	147 000	336 000	2 000	LRBZ 364428
71	73	88	1.5	131 000	298 000	2 000	LRBZ 404824
71	73	88	1.5	154 000	368 000	2 000	LRBZ 404828
77	79	99.9	1.5	193 000	396 000	1 800	LRBZ 445228
77	79	99.9	1.5	214 000	452 000	1 800	LRBZ 445232
83.5	86	106.3	1.5	221 000	488 000	1 700	LRBZ 485632
91	93	112.6	1.5	228 000	522 000	1 600	LRBZ 526032
97	99	119	1.5	237 000	556 000	1 500	LRBZ 566432
103	105	125.3	1.5	242 000	590 000	1 400	LRBZ 606832

D

NA
TAFI
TRI
BRI

MACHINED TYPE NEEDLE ROLLER BEARINGS

With Seal, Without Inner Ring



RNA49...UU
RNA69...UU ($F_w \leq 35$)

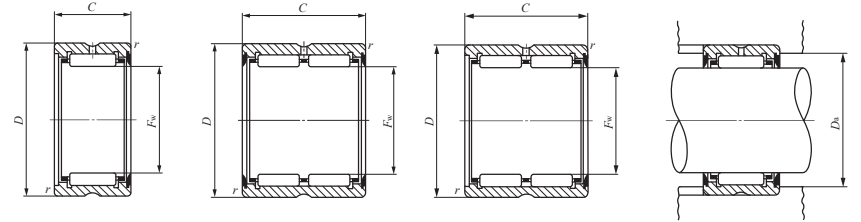

RNA49...U
RNA69...U ($F_w \leq 35$) RNA69...UU RNA69...U

Shaft dia. 14 – 45mm

Shaft dia. mm	Identification number				Mass (Ref.) g	Boundary dimensions mm			
	With two seals	With one seal	With two seals	With one seal		F_w	D	C	r_s min ⁽¹⁾
14	RNA 4900UU	RNA 4900U	—	—	16.3	14	22	13	0.3
16	RNA 4901UU	RNA 4901U	—	—	17.9	16	24	13	0.3
	—	—	RNA 6901UU	RNA 6901U	30	16	24	22	0.3
18	RNA 49/14UU	RNA 49/14U	—	—	19.7	18	26	13	0.3
20	RNA 4902UU	RNA 4902U	—	—	21.5	20	28	13	0.3
	—	—	RNA 6902UU	RNA 6902U	37.5	20	28	23	0.3
22	RNA 4903UU	RNA 4903U	—	—	23	22	30	13	0.3
	—	—	RNA 6903UU	RNA 6903U	40.5	22	30	23	0.3
25	RNA 4904UU	RNA 4904U	—	—	54.5	25	37	17	0.3
	—	—	RNA 6904UU	RNA 6904U	95.5	25	37	30	0.3
28	RNA 49/22UU	RNA 49/22U	—	—	55.5	28	39	17	0.3
	—	—	RNA 69/22UU	RNA 69/22U	97.5	28	39	30	0.3
30	RNA 4905UU	RNA 4905U	—	—	63	30	42	17	0.3
	—	—	RNA 6905UU	RNA 6905U	111	30	42	30	0.3
32	RNA 49/28UU	RNA 49/28U	—	—	75.5	32	45	17	0.3
	—	—	RNA 69/28UU	RNA 69/28U	133	32	45	30	0.3
35	RNA 4906UU	RNA 4906U	—	—	71	35	47	17	0.3
	—	—	RNA 6906UU	RNA 6906U	125	35	47	30	0.3
40	RNA 49/32UU	RNA 49/32U	—	—	94.5	40	52	20	0.6
	—	—	RNA 69/32UU	RNA 69/32U	170	40	52	36	0.6
42	RNA 4907UU	RNA 4907U	—	—	112	42	55	20	0.6
	—	—	RNA 6907UU	RNA 6907U	200	42	55	36	0.6
45	RNA 49/38UU	RNA 49/38U	—	—	119	45	58	20	0.6

Notes⁽¹⁾ Minimum allowable value of chamfer dimension r
⁽²⁾ Allowable rotational speed applies to grease lubrication.

Remarks1. The outer ring has an oil groove and an oil hole.
 2. Bearings with seals on both sides are provided with prepacked grease. Bearings with a seal on one side are not provided with prepacked grease. Perform proper lubrication for use.

Standard mounting dimension D_a Max. mm	Basic dynamic load rating C N	Basic static load rating C_0 N	Allowable rotational speed ⁽²⁾ rpm
20	8 080	8 490	14 000
22	8 470	9 320	12 000
	15 500	20 400	12 000
24	9 260	10 800	11 000
26	9 570	11 600	9 500
	18 500	27 100	9 500
28	10 300	13 100	8 500
	19 800	30 600	8 500
35	18 000	20 500	7 500
	33 000	44 600	7 500
37	18 300	23 700	7 000
	33 800	52 000	7 000
40	20 300	25 100	6 500
	39 200	58 700	6 500
43	21 000	26 800	6 000
	38 900	59 100	6 000
45	21 500	28 400	5 500
	40 100	63 000	5 500
48	29 400	44 200	5 000
	50 300	88 300	5 000
51	30 100	46 300	4 500
	51 600	92 600	4 500
54	31 600	50 400	4 000

D
NA
TAFI
TRI
BRI

MACHINED TYPE NEEDLE ROLLER BEARINGS

With Seal, Without Inner Ring



RNA49...UU

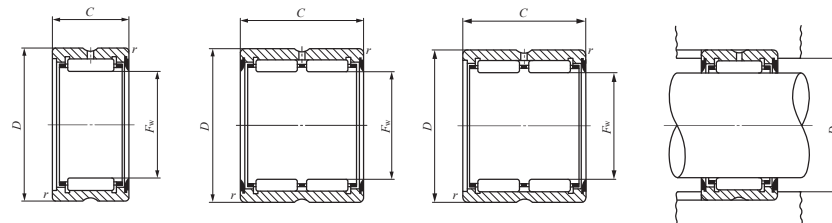

RNA49...U

RNA69...UU

RNA69...U

Shaft dia. 48 – 85mm

Shaft dia. mm	Identification number				Mass (Ref.) g	Boundary dimensions mm				
	With two seals	With one seal	With two seals	With one seal		F_w	D	C	r_s min ⁽¹⁾	
48	RNA 4908UU	RNA 4908U	—	—	150	48	62	22	0.6	
	—	—	RNA 6908UU	RNA 6908U	270	48	62	40	0.6	
50	RNA 49/42UU	RNA 49/42U	—	—	173	50	65	22	0.6	
52	RNA 4909UU	RNA 4909U	—	—	197	52	68	22	0.6	
	—	—	RNA 6909UU	RNA 6909U	355	52	68	40	0.6	
55	RNA 49/48UU	RNA 49/48U	—	—	187	55	70	22	0.6	
58	RNA 4910UU	RNA 4910U	—	—	177	58	72	22	0.6	
	—	—	RNA 6910UU	RNA 6910U	320	58	72	40	0.6	
60	RNA 49/52UU	RNA 49/52U	—	—	200	60	75	22	0.6	
63	RNA 4911UU	RNA 4911U	—	—	265	63	80	25	1	
	—	—	RNA 6911UU	RNA 6911U	470	63	80	45	1	
65	RNA 49/58UU	RNA 49/58U	—	—	275	65	82	25	1	
68	RNA 4912UU	RNA 4912U	—	—	285	68	85	25	1	
	—	—	RNA 6912UU	RNA 6912U	505	68	85	45	1	
70	RNA 49/62UU	RNA 49/62U	—	—	320	70	88	25	1	
72	RNA 4913UU	RNA 4913U	—	—	325	72	90	25	1	
	—	—	RNA 6913UU	RNA 6913U	580	72	90	45	1	
75	RNA 49/68UU	RNA 49/68U	—	—	465	75	95	30	1	
80	RNA 4914UU	RNA 4914U	—	—	495	80	100	30	1	
	—	—	RNA 6914UU	RNA 6914U	910	80	100	54	1	
85	RNA 4915UU	RNA 4915U	—	—	520	85	105	30	1	
	—	—	RNA 6915UU	RNA 6915U	960	85	105	54	1	

Notes⁽¹⁾ Minimum allowable value of chamfer dimension r
⁽²⁾ Allowable rotational speed applies to grease lubrication.

Remarks1. The outer ring has an oil groove and an oil hole.
 2. Bearings with seals on both sides are provided with prepacked grease. Bearings with a seal on one side are not provided with prepacked grease. Perform proper lubrication for use.

Standard mounting dimension D_a Max. mm	Basic dynamic load rating C N	Basic static load rating C_0 N	Allowable rotational speed ⁽²⁾ rpm
58	37 200	58 400	4 000
	63 700	117 000	4 000
61	38 000	60 900	4 000
64	38 900	63 400	3 500
	66 600	127 000	3 500
66	39 600	66 100	3 500
68	41 300	71 100	3 500
	70 800	142 000	3 500
71	42 100	73 600	3 000
75	52 200	85 700	3 000
	89 400	171 000	3 000
77	53 400	89 200	3 000
80	54 500	92 800	3 000
	93 400	186 000	3 000
83	55 700	96 300	2 500
85	56 800	99 800	2 500
	97 400	200 000	2 500
90	73 900	133 000	2 500
95	76 900	143 000	2 500
	124 000	281 000	2 500
100	79 600	153 000	2 000
	128 000	299 000	2 000

D
NA
TAFI
TRI
BRI

MACHINED TYPE NEEDLE ROLLER BEARINGS

With Seal, Without Inner Ring



RNA49...UU

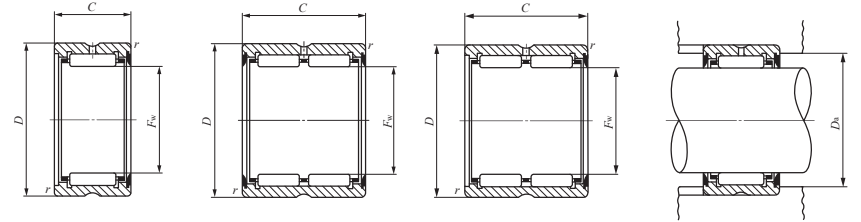

RNA49...U

RNA69...UU

RNA69...U

Shaft dia. 90 – 160mm

Shaft dia. mm	Identification number				Mass (Ref.) g	Boundary dimensions mm			
	With two seals	With one seal	With two seals	With one seal		F_w	D	C	$r_s^{(1)}$
90	RNA 4916UU	RNA 4916U	—	—	545	90	110	30	1
	—	—	RNA 6916UU	RNA 6916U	1 010	90	110	54	1
95	RNA 49/82UU	RNA 49/82U	—	—	570	95	115	30	1
100	RNA 4917UU	RNA 4917U	—	—	695	100	120	35	1.1
	—	—	RNA 6917UU	RNA 6917U	1 300	100	120	63	1.1
105	RNA 4918UU	RNA 4918U	—	—	730	105	125	35	1.1
	—	—	RNA 6918UU	RNA 6918U	1 360	105	125	63	1.1
110	RNA 4919UU	RNA 4919U	—	—	760	110	130	35	1.1
	—	—	RNA 6919UU	RNA 6919U	1 420	110	130	63	1.1
115	RNA 4920UU	RNA 4920U	—	—	1 200	115	140	40	1.1
125	RNA 4922UU	RNA 4922U	—	—	1 280	125	150	40	1.1
135	RNA 4924UU	RNA 4924U	—	—	1 940	135	165	45	1.1
150	RNA 4926UU	RNA 4926U	—	—	2 360	150	180	50	1.5
160	RNA 4928UU	RNA 4928U	—	—	2 510	160	190	50	1.5

Notes⁽¹⁾ Minimum allowable value of chamfer dimension r
⁽²⁾ Allowable rotational speed applies to grease lubrication.

Remarks1. The outer ring has an oil groove and an oil hole.
 2. Bearings with seals on both sides are provided with prepacked grease. Bearings with a seal on one side are not provided with prepacked grease. Perform proper lubrication for use.

Standard mounting dimension D_a Max. mm	Basic dynamic load rating C N	Basic static load rating C_0 N	Allowable rotational speed ⁽²⁾ rpm
105	80 700	158 000	2 000
105	132 000	317 000	2 000
110	83 200	168 000	2 000
113.5	103 000	225 000	1 900
113.5	168 000	448 000	1 900
118.5	106 000	238 000	1 800
118.5	172 000	471 000	1 800
123.5	109 000	250 000	1 700
123.5	177 000	493 000	1 700
133.5	134 000	297 000	1 700
143.5	140 000	322 000	1 500
158.5	178 000	410 000	1 400
172	206 000	511 000	1 300
182	214 000	549 000	1 200

D

NA
TAFI
TRI
BRI

MACHINED TYPE NEEDLE ROLLER BEARINGS

With Seal, With Inner Ring

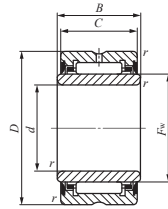

NA49...UU
NA69...UU($d \leq 30$)

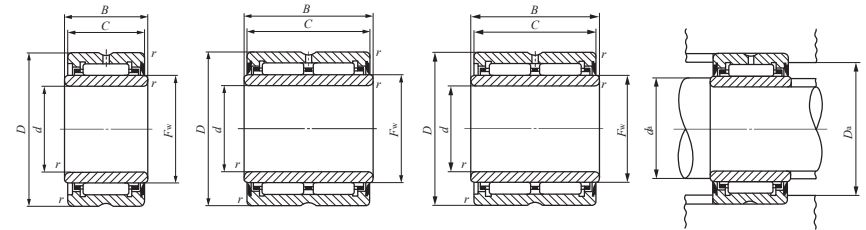

NA49...U
NA69...U($d \leq 30$) NA69...UU NA69...U

Shaft dia. 10 – 40mm

Shaft dia. mm	Identification number				Mass (Ref.) g	Boundary dimensions mm			
	With two seals	With one seal	With two seals	With one seal		d	D	C	B
10	NA 4900UU	NA 4900U	—	—	24.5	10	22	13	14
12	NA 4901UU	NA 4901U	—	—	27.5	12	24	13	14
	—	—	NA 6901UU	NA 6901U	45.5	12	24	22	23
15	NA 4902UU	NA 4902U	—	—	36	15	28	13	14
	—	—	NA 6902UU	NA 6902U	62.5	15	28	23	24
17	NA 4903UU	NA 4903U	—	—	39.5	17	30	13	14
	—	—	NA 6903UU	NA 6903U	68.5	17	30	23	24
20	NA 4904UU	NA 4904U	—	—	78.5	20	37	17	18
	—	—	NA 6904UU	NA 6904U	137	20	37	30	31
22	NA 49/22UU	NA 49/22U	—	—	87.5	22	39	17	18
	—	—	NA 69/22UU	NA 69/22U	153	22	39	30	31
25	NA 4905UU	NA 4905U	—	—	92.5	25	42	17	18
	—	—	NA 6905UU	NA 6905U	162	25	42	30	31
28	NA 49/28UU	NA 49/28U	—	—	101	28	45	17	18
	—	—	NA 69/28UU	NA 69/28U	177	28	45	30	31
30	NA 4906UU	NA 4906U	—	—	106	30	47	17	18
	—	—	NA 6906UU	NA 6906U	185	30	47	30	31
32	NA 49/32UU	NA 49/32U	—	—	167	32	52	20	21
	—	—	NA 69/32UU	NA 69/32U	300	32	52	36	37
35	NA 4907UU	NA 4907U	—	—	179	35	55	20	21
	—	—	NA 6907UU	NA 6907U	320	35	55	36	37
40	NA 4908UU	NA 4908U	—	—	245	40	62	22	23
	—	—	NA 6908UU	NA 6908U	440	40	62	40	41

Notes⁽¹⁾ Minimum allowable value of chamfer dimension r
⁽²⁾ Allowable rotational speed applies to grease lubrication.

Remarks1. The outer ring has an oil groove and an oil hole.
 2. Bearings with seals on both sides are provided with prepacked grease. Bearings with a seal on one side are not provided with prepacked grease. Perform proper lubrication for use.

r_s ⁽¹⁾ mm	F_w	Standard mounting dimensions mm			Basic dynamic load rating C N	Basic static load rating C_0 N	Allowable rotational speed ⁽²⁾ rpm	Assembled inner ring
		Min.	Max.	Max.				
0.3	14	12	13	20	8 080	8 490	14 000	LRTZ 101414
0.3	16	14	15	22	8 470	9 320	12 000	LRTZ 121614
	16	14	15	22	15 500	20 400	12 000	LRTZ 121623
0.3	20	17	19	26	9 570	11 600	9 500	LRTZ 152014
	20	17	19	26	18 500	27 100	9 500	LRTZ 152024
0.3	22	19	21	28	10 300	13 100	8 500	LRTZ 172214
	22	19	21	28	19 800	30 600	8 500	LRTZ 172224
0.3	25	22	24	35	18 000	20 500	7 500	LRTZ 202518
	25	22	24	35	33 000	44 600	7 500	LRTZ 202531
0.3	28	24	27	37	18 300	23 700	7 000	LRTZ 222818
	28	24	27	37	33 800	52 000	7 000	LRTZ 222831
0.3	30	27	29	40	20 300	25 100	6 500	LRTZ 253018
	30	27	29	40	39 200	58 700	6 500	LRTZ 253031
0.3	32	30	31	43	21 000	26 800	6 000	LRTZ 283218
	32	30	31	43	38 900	59 100	6 000	LRTZ 283231
0.3	35	32	34	45	21 500	28 400	5 500	LRTZ 303518
	35	32	34	45	40 100	63 000	5 500	LRTZ 303531
0.6	40	36	39	48	29 400	44 200	5 000	LRTZ 324021
	40	36	39	48	50 300	88 300	5 000	LRTZ 324037
0.6	42	39	41	51	30 100	46 300	4 500	LRTZ 354221
	42	39	41	51	51 600	92 600	4 500	LRTZ 354237
0.6	48	44	47	58	37 200	58 400	4 000	LRTZ 404823
	48	44	47	58	63 700	117 000	4 000	LRTZ 404841

D

NA
TAFI
TRI
BRI

MACHINED TYPE NEEDLE ROLLER BEARINGS

With Seal, With Inner Ring

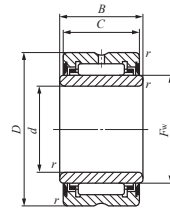

NA49...UU

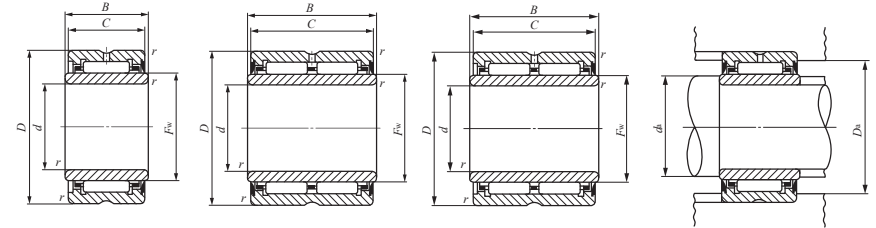

NA49...U

NA69...UU

NA69...U

Shaft dia. 45 – 110mm

Shaft dia. mm	Identification number				Mass (Ref.) g	Boundary dimensions mm			
	With two seals	With one seal	With two seals	With one seal		d	D	C	B
45	NA 4909UU	NA 4909U	—	—	290	45	68	22	23
	—	—	NA 6909UU	NA 6909U	520	45	68	40	41
50	NA 4910UU	NA 4910U	—	—	295	50	72	22	23
	—	—	NA 6910UU	NA 6910U	530	50	72	40	41
55	NA 4911UU	NA 4911U	—	—	415	55	80	25	26
	—	—	NA 6911UU	NA 6911U	730	55	80	45	46
60	NA 4912UU	NA 4912U	—	—	445	60	85	25	26
	—	—	NA 6912UU	NA 6912U	785	60	85	45	46
65	NA 4913UU	NA 4913U	—	—	475	65	90	25	26
	—	—	NA 6913UU	NA 6913U	845	65	90	45	46
70	NA 4914UU	NA 4914U	—	—	770	70	100	30	31
	—	—	NA 6914UU	NA 6914U	1 400	70	100	54	55
75	NA 4915UU	NA 4915U	—	—	815	75	105	30	31
	—	—	NA 6915UU	NA 6915U	1 480	75	105	54	55
80	NA 4916UU	NA 4916U	—	—	860	80	110	30	31
	—	—	NA 6916UU	NA 6916U	1 570	80	110	54	55
85	NA 4917UU	NA 4917U	—	—	1 300	85	120	35	36
	—	—	NA 6917UU	NA 6917U	2 360	85	120	63	64
90	NA 4918UU	NA 4918U	—	—	1 360	90	125	35	36
	—	—	NA 6918UU	NA 6918U	2 480	90	125	63	64
95	NA 4919UU	NA 4919U	—	—	1 420	95	130	35	36
	—	—	NA 6919UU	NA 6919U	2 600	95	130	63	64
100	NA 4920UU	NA 4920U	—	—	1 980	100	140	40	41
110	NA 4922UU	NA 4922U	—	—	2 150	110	150	40	41

Notes⁽¹⁾ Minimum allowable value of chamfer dimension r

⁽²⁾ Allowable rotational speed applies to grease lubrication.

Remarks1. The outer ring has an oil groove and an oil hole.

2. Bearings with seals on both sides are provided with prepacked grease. Bearings with a seal on one side are not provided with prepacked grease. Perform proper lubrication for use.

r_s min ⁽¹⁾	F_w	Standard mounting dimensions mm			Basic dynamic load rating C N	Basic static load rating C_0 N	Allowable rotational speed ⁽²⁾ rpm	Assembled inner ring	
		Min.	Max.	Max.				LRTZ	Part No.
0.6	52	49	51	64	38 900	63 400	3 500	LRTZ	455223
0.6	52	49	51	64	66 600	127 000	3 500	LRTZ	455241
0.6	58	54	57	68	41 300	71 100	3 500	LRTZ	505823
0.6	58	54	57	68	70 800	142 000	3 500	LRTZ	505841
1	63	60	61	75	52 200	85 700	3 000	LRTZ	556326
1	63	60	61	75	89 400	171 000	3 000	LRTZ	556346
1	68	65	66	80	54 500	92 800	3 000	LRTZ	606826
1	68	65	66	80	93 400	186 000	3 000	LRTZ	606846
1	72	70	70.5	85	56 800	99 800	2 500	LRTZ	657226
1	72	70	70.5	85	97 400	200 000	2 500	LRTZ	657246
1	80	75	78	95	76 900	143 000	2 500	LRTZ	708031
1	80	75	78	95	124 000	281 000	2 500	LRTZ	708055
1	85	80	83	100	79 600	153 000	2 000	LRTZ	758531
1	85	80	83	100	128 000	299 000	2 000	LRTZ	758555
1	90	85	88	105	80 700	158 000	2 000	LRTZ	809031
1	90	85	88	105	132 000	317 000	2 000	LRTZ	809055
1.1	100	91.5	98	113.5	103 000	225 000	1 900	LRTZ	8510036
1.1	100	91.5	98	113.5	168 000	448 000	1 900	LRTZ	8510064
1.1	105	96.5	103	118.5	106 000	238 000	1 800	LRTZ	9010536
1.1	105	96.5	103	118.5	172 000	471 000	1 800	LRTZ	9010564
1.1	110	101.5	108	123.5	109 000	250 000	1 700	LRTZ	9511036
1.1	110	101.5	108	123.5	177 000	493 000	1 700	LRTZ	9511064
1.1	115	106.5	113	133.5	134 000	297 000	1 700	LRTZ	10011541
1.1	125	116.5	123	143.5	140 000	322 000	1 500	LRTZ	11012541

D
NA
TAFI
TRI
BRI

MACHINED TYPE NEEDLE ROLLER BEARINGS

With Seal, With Inner Ring

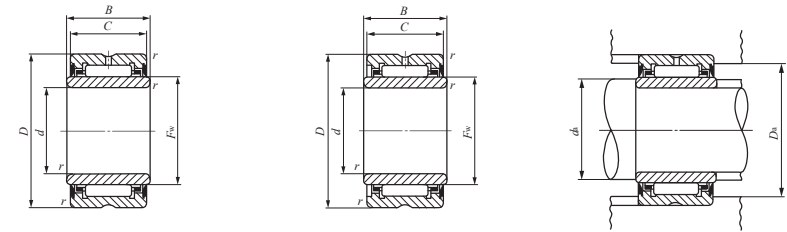

NA49...UU

NA49...U

Shaft dia. 120 – 140mm

Shaft dia. mm	Identification number				Mass (Ref.) g	Boundary dimensions mm			
	With two seals	With one seal	With two seals	With one seal		<i>d</i>	<i>D</i>	<i>C</i>	<i>B</i>
120	NA 4924UU	NA 4924U	—	—	2 990	120	165	45	46
130	NA 4926UU	NA 4926U	—	—	4 080	130	180	50	51
140	NA 4928UU	NA 4928U	—	—	4 340	140	190	50	51

Notes⁽¹⁾ Minimum allowable value of chamfer dimension *r*
⁽²⁾ Allowable rotational speed applies to grease lubrication.

Remarks1. The outer ring has an oil groove and an oil hole.
 2. Bearings with seals on both sides are provided with prepacked grease. Bearings with a seal on one side are not provided with prepacked grease. Perform proper lubrication for use.

<i>r_s</i> min ⁽¹⁾	<i>F_w</i>	Standard mounting dimensions mm			Basic dynamic load rating <i>C</i> N	Basic static load rating <i>C₀</i> N	Allowable rotational speed ⁽²⁾ rpm	Assembled inner ring
		<i>d_a</i>		<i>D_a</i>				
		Min.	Max.	Max.				
1.1	135	126.5	133	158.5	178 000	410 000	1 400	LRTZ 12013546
1.5	150	138	148	172	206 000	511 000	1 300	LRTZ 13015051
1.5	160	148	158	182	214 000	549 000	1 200	LRTZ 14016051

D

NA
TAFI
TRI
BRI

MACHINED TYPE NEEDLE ROLLER BEARINGS

With Seal, Without Inner Ring, Inch Series

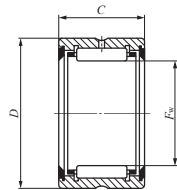

BR ... UU

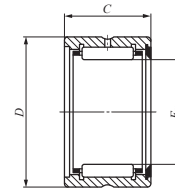

BR ... U

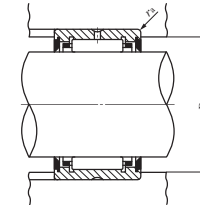

Shaft dia. 15.875 – 50.800mm

Shaft dia. mm (inch)	Identification number		Mass (Ref.) g	Boundary dimensions mm(inch)		
	With two seals	With one seal		F_w	D	C
15.875 (5/8)	BR 101816 UU	BR 101816 U	54	15.875 (5/8)	28.575 (1 1/8)	25.400 (1)
19.050 (3/4)	BR 122016 UU	BR 122016 U	68	19.050 (3/4)	31.750 (1 1/4)	25.400 (1)
22.225 (7/8)	BR 142216 UU	BR 142216 U	76	22.225 (7/8)	34.925 (1 3/8)	25.400 (1)
25.400 (1)	BR 162416 UU	BR 162416 U	83	25.400 (1)	38.100 (1 1/2)	25.400 (1)
28.575 (1 1/8)	BR 182620 UU	BR 182620 U	115	28.575 (1 1/8)	41.275 (1 5/8)	31.750 (1 1/4)
31.750 (1 1/4)	BR 202820 UU	BR 202820 U	124	31.750 (1 1/4)	44.450 (1 3/4)	31.750 (1 1/4)
34.925 (1 3/8)	BR 223020 UU	BR 223020 U	134	34.925 (1 3/8)	47.625 (1 7/8)	31.750 (1 1/4)
38.100 (1 1/2)	BR 243320 UU	BR 243320 U	168	38.100 (1 1/2)	52.388 (2 1/16)	31.750 (1 1/4)
41.275 (1 5/8)	BR 263520 UU	BR 263520 U	179	41.275 (1 5/8)	55.562 (2 3/16)	31.750 (1 1/4)
44.450 (1 3/4)	BR 283720 UU	BR 283720 U	193	44.450 (1 3/4)	58.738 (2 5/16)	31.750 (1 1/4)
47.625 (1 7/8)	BR 303920 UU	BR 303920 U	202	47.625 (1 7/8)	61.912 (2 7/16)	31.750 (1 1/4)
50.800 (2)	BR 324120 UU	BR 324120 U	216	50.800 (2)	65.088 (2 9/16)	31.750 (1 1/4)

Notes⁽¹⁾ Maximum permissible corner radius of the housing
⁽²⁾ Allowable rotational speed applies to grease lubrication.

Remarks1. The outer ring has an oil groove and an oil hole.
 2. Bearings with seals on both sides are provided with prepacked grease. Bearings with a seal on one side are not provided with prepacked grease. Perform proper lubrication for use.

Standard mounting dimensions mm		Basic dynamic load rating C N	Basic static load rating C_0 N	Allowable rotational speed ⁽²⁾ rpm
D_a Max.	$r_{as\ max}^{(1)}$			
24.5	0.6	18 300	20 000	12 000
26.5	1.0	20 700	24 400	10 000
29.7	1.0	21 600	26 900	9 000
32.9	1.0	23 600	31 300	8 000
36.0	1.0	34 900	49 900	7 000
39.2	1.0	36 000	53 500	6 500
42.4	1.0	38 500	60 000	5 500
45.1	1.5	43 700	66 900	5 500
48.3	1.5	44 800	70 900	4 500
51.5	1.5	47 500	78 200	4 500
54.7	1.5	48 500	82 100	4 000
57.8	1.5	51 000	89 400	4 000

D

NA
TAFI
TRI
BRI

MACHINED TYPE NEEDLE ROLLER BEARINGS

With Seal, Without Inner Ring, Inch Series

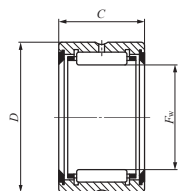

BR ... UU

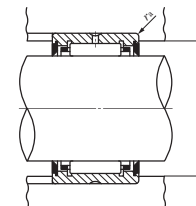
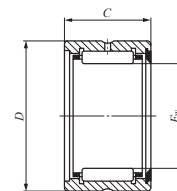

BR ... U

Shaft dia. 57.150 – 95.250mm

Shaft dia. mm (inch)	Identification number		Mass (Ref.) g	Boundary dimensions mm(inch)		
	With two seals	With one seal		F_w	D	C
57.150 (2 1/4)	BR 364828 UU	BR 364828 U	459	57.150 (2 1/4)	76.200 (3)	44.450 (1 3/4)
63.500 (2 1/2)	BR 405228 UU	BR 405228 U	499	63.500 (2 1/2)	82.550 (3 1/4)	44.450 (1 3/4)
69.850 (2 3/4)	BR 445628 UU	BR 445628 U	540	69.850 (2 3/4)	88.900 (3 1/2)	44.450 (1 3/4)
76.200 (3)	BR 486028 UU	BR 486028 U	585	76.200 (3)	95.250 (3 3/4)	44.450 (1 3/4)
82.550 (3 1/4)	BR 526828 UU	BR 526828 U	891	82.550 (3 1/4)	107.950 (4 1/4)	44.450 (1 3/4)
88.900 (3 1/2)	BR 567232 UU	BR 567232 U	1 098	88.900 (3 1/2)	114.300 (4 1/2)	50.800 (2)
95.250 (3 3/4)	BR 607632 UU	BR 607632 U	1 161	95.250 (3 3/4)	120.650 (4 3/4)	50.800 (2)

Notes⁽¹⁾ Maximum permissible corner radius of the housing
⁽²⁾ Allowable rotational speed applies to grease lubrication.

Remarks1. The outer ring has an oil groove and an oil hole.
 2. Bearings with seals on both sides are provided with prepacked grease. Bearings with a seal on one side are not provided with prepacked grease. Perform proper lubrication for use.

Standard mounting dimensions mm		Basic dynamic load rating	Basic static load rating	Allowable rotational speed ⁽²⁾ rpm
D_a Max.	$r_{as \text{ max}}^{(1)}$	C N	C_0 N	
69.0	1.5	90 300	158 000	3 500
74.3	2.0	94 600	174 000	3 000
80.7	2.0	98 700	189 000	2 500
87.0	2.0	105 000	211 000	2 500
99.7	2.0	109 000	227 000	2 500
106.1	2.0	142 000	265 000	2 000
111.4	2.5	148 000	287 000	2 000

D

NA
TAFI
TRI
BRI

MACHINED TYPE NEEDLE ROLLER BEARINGS

With Seal, With Inner Ring, Inch Series

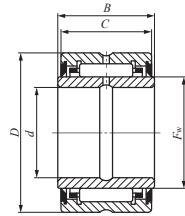

BRI ... UU

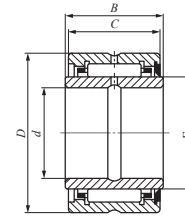

BRI ... U

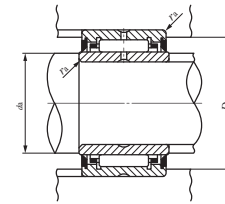

Shaft dia. 9.525 – 44.450mm

Shaft dia. mm (inch)	Identification number		Mass (Ref.) g	Boundary dimensions mm(inch)			
	With two seals	With one seal		d	D	C	B
9.525 (3/8)	BRI 61816 UU	BRI 61816 U	79	9.525 (3/8)	28.575 (1 1/8)	25.400 (1)	25.650
12.700 (1/2)	BRI 82016 UU	BRI 82016 U	99	12.700 (1/2)	31.750 (1 1/4)	25.400 (1)	25.650
15.875 (5/8)	BRI 102216 UU	BRI 102216 U	113.5	15.875 (5/8)	34.925 (1 3/8)	25.400 (1)	25.650
19.050 (3/4)	BRI 122416 UU	BRI 122416 U	127	19.050 (3/4)	38.100 (1 1/2)	25.400 (1)	25.650
22.225 (7/8)	BRI 142620 UU	BRI 142620 U	177	22.225 (7/8)	41.275 (1 5/8)	31.750 (1 1/4)	32.000
25.400 (1)	BRI 162820 UU	BRI 162820 U	196	25.400 (1)	44.450 (1 3/4)	31.750 (1 1/4)	32.000
28.575 (1 1/8)	BRI 183020 UU	BRI 183020 U	211	28.575 (1 1/8)	47.625 (1 7/8)	31.750 (1 1/4)	32.000
31.750 (1 1/4)	BRI 203320 UU	BRI 203320 U	254	31.750 (1 1/4)	52.388 (2 1/16)	31.750 (1 1/4)	32.000
34.925 (1 3/8)	BRI 223520 UU	BRI 223520 U	275	34.925 (1 3/8)	55.562 (2 3/16)	31.750 (1 1/4)	32.000
38.100 (1 1/2)	BRI 243720 UU BRI 243920 UU	BRI 243720 U BRI 243920 U	293 362	38.100 (1 1/2) 38.100 (1 1/2)	58.738 (2 3/16) 61.912 (2 7/16)	31.750 (1 1/4) 31.750 (1 1/4)	32.000 32.000
41.275 (1 5/8)	BRI 264120 UU	BRI 264120 U	386	41.275 (1 5/8)	65.088 (2 9/16)	31.750 (1 1/4)	32.000
44.450 (1 3/4)	BRI 284828 UU	BRI 284828 U	804	44.450 (1 3/4)	76.200 (3)	44.450 (1 3/4)	44.700

Notes⁽¹⁾ Maximum permissible corner radius of the shaft or housing
⁽²⁾ Allowable rotational speed applies to grease lubrication.

Remarks1. The inner ring and the outer ring each have an oil groove and an oil hole.
 2. Bearings with seals on both sides are provided with prepacked grease. Bearings with a seal on one side are not provided with prepacked grease. Perform proper lubrication for use.

F _w	Standard mounting dimensions mm				Basic dynamic load rating C N	Basic static load rating C ₀ N	Allowable rotational speed ⁽²⁾ rpm	Assembled inner ring
	d _a Min.	d _a Max.	D _a Max.	r _{as max} ⁽¹⁾				
15.875 (5/8)	14	14.5	24.5	0.6	18 300	20 000	12 000	LRBZ 61016 B
19.050 (3/4)	17.5	18	26.5	0.6	20 700	24 400	10 000	LRBZ 81216 B
22.225 (7/8)	21	21.2	29.7	0.6	21 600	26 900	9 000	LRBZ 101416 B
25.400 (1)	24	24.4	32.9	0.6	23 600	31 300	8 000	LRBZ 121616 B
28.575 (1 1/8)	27	27.5	36.0	0.6	34 900	49 900	7 000	LRBZ 141820 B
31.750 (1 1/4)	30.5	30.7	39.2	0.6	36 000	53 500	6 500	LRBZ 162020 B
34.925 (1 3/8)	33.5	33.9	42.4	0.6	38 500	60 000	5 500	LRBZ 182220 B
38.100 (1 1/2)	37	37.1	45.1	0.6	43 700	66 900	5 500	LRBZ 202420 B
41.275 (1 5/8)	40.2	40.2	48.3	0.6	44 800	70 900	4 500	LRBZ 222620 B
44.450 (1 3/4)	43.3	43.4	51.5	0.6	47 500	78 200	4 500	LRBZ 242820 B
47.625 (1 7/8)	43.3	45	54.7	1	48 500	82 100	4 000	LRBZ 243020 B
50.800 (2)	48	49	57.8	1	51 000	89 400	4 000	LRBZ 263220 B
57.150 (2 1/4)	52.5	55	69.0	1.5	90 300	158 000	3 500	LRBZ 283628 B

D

NA
TAFI
TRI
BRI

MACHINED TYPE NEEDLE ROLLER BEARINGS

With Seal, With Inner Ring, Inch Series

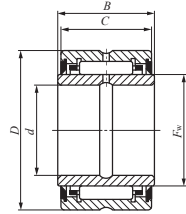

BRI ... UU

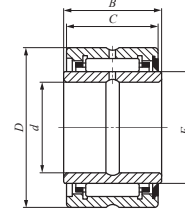

BRI ... U

Shaft dia. 50.800 – 82.550mm

Shaft dia. mm (inch)	Identification number		Mass (Ref.) g	Boundary dimensions mm(inch)			
	With two seals	With one seal		<i>d</i>	<i>D</i>	<i>C</i>	<i>B</i>
50.800 (2)	BRI 325228 UU	BRI 325228 U	889	50.800(2)	82.550(3 1/4)	44.450(1 3/4)	44.700
57.150 (2 1/4)	BRI 365628 UU	BRI 365628 U	980	57.150(2 1/4)	88.900(3 1/2)	44.450(1 3/4)	44.700
63.500 (2 1/2)	BRI 406028 UU	BRI 406028 U	1 065	63.500(2 1/2)	95.250(3 3/4)	44.450(1 3/4)	44.700
69.850 (2 3/4)	BRI 446828 UU	BRI 446828 U	1 421	69.850(2 3/4)	107.950(4 1/4)	44.450(1 3/4)	44.700
76.200 (3)	BRI 487232 UU	BRI 487232 U	1 738	76.200(3)	114.300(4 1/2)	50.800(2)	51.050
82.550 (3 1/4)	BRI 527632 UU	BRI 527632 U	1 851	82.550(3 1/4)	120.650(4 3/4)	50.800(2)	51.050

Notes⁽¹⁾ Maximum permissible corner radius of the shaft or housing
⁽²⁾ Allowable rotational speed applies to grease lubrication.

Remarks1. The inner ring and the outer ring each have an oil groove and an oil hole.
 2. Bearings with seals on both sides are provided with prepacked grease. Bearings with a seal on one side are not provided with prepacked grease. Perform proper lubrication for use.

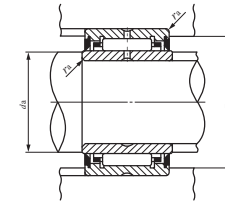

<i>F_w</i>	Standard mounting dimensions mm				Basic dynamic load rating <i>C</i> N	Basic static load rating <i>C₀</i> N	Allowable rotational speed ⁽²⁾ rpm	Assembled inner ring
	<i>d_a</i>		<i>D_a</i>	<i>r_{as max}</i> ⁽¹⁾				
	Min.	Max.	Max.					
63.500(2 1/2)	58	61	74.3	1.5	94 600	174 000	3 000	LRBZ 324028 B
69.850(2 3/4)	65	67	80.7	1.5	98 700	189 000	2 500	LRBZ 364428 B
76.200(3)	71	73	87.0	1.5	105 000	211 000	2 500	LRBZ 404828 B
82.550(3 1/4)	77	79	99.7	1.5	109 000	227 000	2 500	LRBZ 445228 B
88.900(3 1/2)	83.5	86	106.1	1.5	142 000	265 000	2 000	LRBZ 485632 B
95.250(3 3/4)	91	93	111.4	1.5	148 000	287 000	2 000	LRBZ 526032 B

D

NA
TAFI
TRI
BRI

MACHINED TYPE NEEDLE ROLLER BEARINGS

With Seal, Without Inner Ring, Inch Series

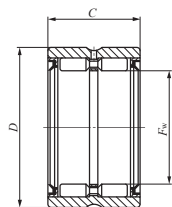

GBR ... UU

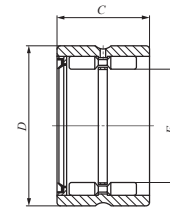

GBR ... U

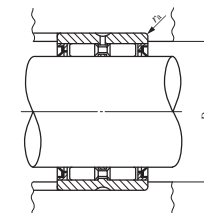

Shaft dia. 15.875 – 50.800mm

Shaft dia. mm (inch)	Identification number		Mass (Ref.) g	Boundary dimensions mm(inch)		
	With two seals	With one seal		F_w	D	C
15.875 (5/8)	GBR 101816 UU	GBR 101816 U	69.5	15.875 (5/8)	28.575 (1 1/8)	25.400 (1)
19.050 (3/4)	GBR 122016 UU	GBR 122016 U	79	19.050 (3/4)	31.750 (1 1/4)	25.400 (1)
22.225 (7/8)	GBR 142216 UU	GBR 142216 U	89.5	22.225 (7/8)	34.925 (1 3/8)	25.400 (1)
25.400 (1)	GBR 162416 UU	GBR 162416 U	99	25.400 (1)	38.100 (1 1/2)	25.400 (1)
28.575 (1 1/8)	GBR 182620 UU	GBR 182620 U	139	28.575 (1 1/8)	41.275 (1 5/8)	31.750 (1 1/4)
31.750 (1 1/4)	GBR 202820 UU	GBR 202820 U	152	31.750 (1 1/4)	44.450 (1 3/4)	31.750 (1 1/4)
34.925 (1 3/8)	GBR 223020 UU	GBR 223020 U	163	34.925 (1 3/8)	47.625 (1 7/8)	31.750 (1 1/4)
38.100 (1 1/2)	GBR 243320 UU	GBR 243320 U	200	38.100 (1 1/2)	52.388 (2 1/16)	31.750 (1 1/4)
41.275 (1 5/8)	GBR 263520 UU	GBR 263520 U	215	41.275 (1 5/8)	55.562 (2 3/16)	31.750 (1 1/4)
44.450 (1 3/4)	GBR 283720 UU	GBR 283720 U	230	44.450 (1 3/4)	58.738 (2 5/16)	31.750 (1 1/4)
47.625 (1 7/8)	GBR 303920 UU	GBR 303920 U	240	47.625 (1 7/8)	61.912 (2 7/16)	31.750 (1 1/4)
50.800 (2)	GBR 324120 UU	GBR 324120 U	255	50.800 (2)	65.088 (2 9/16)	31.750 (1 1/4)

Notes⁽¹⁾ Maximum permissible corner radius of the shaft or housing
⁽²⁾ Allowable rotational speed applies to grease lubrication.

Remarks1. The outer ring has an oil groove and an oil hole.
 2. Bearings with seals on both sides are provided with prepacked grease. Bearings with a seal on one side are not provided with prepacked grease. Perform proper lubrication for use.

Standard mounting dimensions mm		Basic dynamic load rating C N	Basic static load rating C_0 N	Allowable rotational speed ⁽²⁾ rpm
D_a Max.	$r_{as \text{ max}}^{(1)}$			
24.5	0.6	23 500	28 500	5 000
27	0.6	26 400	34 500	4 000
30	0.6	28 600	40 100	3 500
33.3	0.6	31 000	46 100	3 000
36.3	0.6	43 900	75 300	3 000
39.6	0.6	46 600	83 900	2 500
42.8	0.6	49 500	91 800	2 500
47.3	0.6	54 200	97 700	2 000
50.5	0.6	56 600	105 000	1 900
53.7	0.6	58 900	114 000	1 800
56.2	1	61 100	121 000	1 700
59.2	1	63 100	130 000	1 600

D
 NA
 TAFI
 TRI
 BRI

MACHINED TYPE NEEDLE ROLLER BEARINGS

With Seal, Without Inner Ring, Inch Series

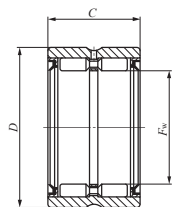

GBR ... UU

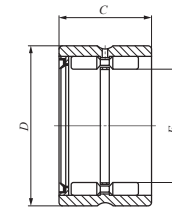

GBR ... U

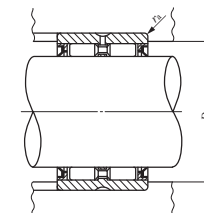

Shaft dia. 57.150 – 107.950mm

Shaft dia. mm (inch)	Identification number		Mass (Ref.) g	Boundary dimensions mm(inch)		
	With two seals	With one seal		F_w	D	C
57.150 (2 1/4)	GBR 364828 UU	GBR 364828 U	515	57.150 (2 1/4)	76.200 (3)	44.450 (1 3/4)
63.500 (2 1/2)	GBR 405228 UU	GBR 405228 U	560	63.500 (2 1/2)	82.550 (3 1/4)	44.450 (1 3/4)
69.850 (2 3/4)	GBR 445628 UU	GBR 445628 U	610	69.850 (2 3/4)	88.900 (3 1/2)	44.450 (1 3/4)
76.200 (3)	GBR 486028 UU	GBR 486028 U	660	76.200 (3)	95.250 (3 3/4)	44.450 (1 3/4)
82.550 (3 1/4)	GBR 526828 UU	GBR 526828 U	960	82.550 (3 1/4)	107.950 (4 1/4)	44.450 (1 3/4)
88.900 (3 1/2)	GBR 567232 UU	GBR 567232 U	1 240	88.900 (3 1/2)	114.300 (4 1/2)	50.800 (2)
95.250 (3 3/4)	GBR 607632 UU	GBR 607632 U	1 320	95.250 (3 3/4)	120.650 (4 3/4)	50.800 (2)
101.600 (4)	GBR 648032 UU	GBR 648032 U	1 380	101.600 (4)	127.000 (5)	50.800 (2)
107.950 (4 1/4)	GBR 688432 UU	GBR 688432 U	1 460	107.950 (4 1/4)	133.350 (5 1/4)	50.800 (2)

Notes⁽¹⁾ Maximum permissible corner radius of the shaft or housing
⁽²⁾ Allowable rotational speed applies to grease lubrication.

Remarks 1. The outer ring has an oil groove and an oil hole.
 2. Bearings with seals on both sides are provided with prepacked grease. Bearings with a seal on one side are not provided with prepacked grease. Perform proper lubrication for use.

Standard mounting dimensions mm		Basic dynamic load rating C N	Basic static load rating C_0 N	Allowable rotational speed ⁽²⁾ rpm
D_a Max.	$r_{as \text{ max}}^{(1)}$			
69.2	1.5	87 500	161 000	1 400
75.7	1.5	93 300	179 000	1 300
82	1.5	97 200	197 000	1 100
88	1.5	101 000	215 000	1 100
99.9	1.5	127 000	231 000	950
106.3	1.5	170 000	347 000	900
112.6	1.5	175 000	371 000	850
119	1.5	182 000	395 000	800
125.3	1.5	186 000	419 000	750

D
NA
TAFI
TRI
BRI

MACHINED TYPE NEEDLE ROLLER BEARINGS

With Seal, With Inner Ring, Inch Series

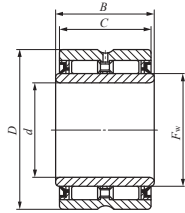

GBRI...UU

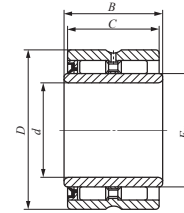

GBRI...U

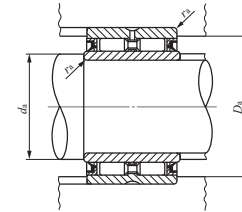

Shaft dia. 9.525 – 44.450mm

Shaft dia. mm (inch)	Identification number		Mass (Ref.) g	Boundary dimensions mm(inch)		
	With two seals	With one seal		d	D	C
9.525 (³ / ₈)	GBRI 61816 UU	GBRI 61816 U	94.5	9.525(³ / ₈)	28.575(1 ¹ / ₈)	25.400(1)
12.700 (¹ / ₂)	GBRI 82016 UU	GBRI 82016 U	110	12.700(¹ / ₂)	31.750(1 ¹ / ₄)	25.400(1)
15.875 (⁵ / ₈)	GBRI 102216 UU	GBRI 102216 U	127	15.875(⁵ / ₈)	34.925(1 ³ / ₈)	25.400(1)
19.050 (³ / ₄)	GBRI 122416 UU	GBRI 122416 U	143	19.050(³ / ₄)	38.100(1 ¹ / ₂)	25.400(1)
22.225 (⁷ / ₈)	GBRI 142620 UU	GBRI 142620 U	200	22.225(⁷ / ₈)	41.275(1 ⁵ / ₈)	31.750(1 ¹ / ₄)
25.400 (1)	GBRI 162820 UU	GBRI 162820 U	220	25.400(1)	44.450(1 ³ / ₄)	31.750(1 ¹ / ₄)
28.575 (1 ¹ / ₈)	GBRI 183020 UU	GBRI 183020 U	240	28.575(1 ¹ / ₈)	47.625(1 ⁷ / ₈)	31.750(1 ¹ / ₄)
31.750 (1 ¹ / ₄)	GBRI 203320 UU	GBRI 203320 U	286	31.750(1 ¹ / ₄)	52.388(2 ¹ / ₁₆)	31.750(1 ¹ / ₄)
34.925 (1 ³ / ₈)	GBRI 223520 UU	GBRI 223520 U	311	34.925(1 ³ / ₈)	55.562(2 ³ / ₁₆)	31.750(1 ¹ / ₄)
38.100 (1 ¹ / ₂)	GBRI 243720 UU GBRI 243920 UU	GBRI 243720 U GBRI 243920 U	330 400	38.100(1 ¹ / ₂) 38.100(1 ¹ / ₂)	58.738(2 ³ / ₁₆) 61.912(2 ⁷ / ₁₆)	31.750(1 ¹ / ₄) 31.750(1 ¹ / ₄)
41.275 (1 ⁵ / ₈)	GBRI 264120 UU	GBRI 264120 U	425	41.275(1 ⁵ / ₈)	65.088(2 ⁹ / ₁₆)	31.750(1 ¹ / ₄)
44.450 (1 ³ / ₄)	GBRI 284828 UU	GBRI 284828 U	860	44.450(1 ³ / ₄)	76.200(3)	44.450(1 ³ / ₄)

Notes⁽¹⁾ Maximum permissible corner radius of the shaft or housing
⁽²⁾ Allowable rotational speed applies to grease lubrication.

Remarks1. The outer ring has an oil groove and an oil hole.
 2. Bearings with seals on both sides are provided with prepacked grease. Bearings with a seal on one side are not provided with prepacked grease. Perform proper lubrication for use.

B	F _w	Standard mounting dimensions mm				Basic dynamic load rating C N	Basic static load rating C ₀ N	Allowable rotational speed ⁽²⁾ rpm	Assembled inner ring
		d _a Min.	d _a Max.	D _a Max.	r _{as max} ⁽¹⁾				
25.650	15.875(⁵ / ₈)	14	14.5	24.5	0.6	23 500	28 500	5 000	LRBZ 61016
25.650	19.050(³ / ₄)	17.5	18	27	0.6	26 400	34 500	4 000	LRBZ 81216
25.650	22.225(⁷ / ₈)	21	21.2	30	0.6	28 600	40 100	3 500	LRBZ 101416
25.650	25.400(1)	24	24.4	33.3	0.6	31 000	46 100	3 000	LRBZ 121616
32.000	28.575(1 ¹ / ₈)	27	27.5	36.3	0.6	43 900	75 300	3 000	LRBZ 141820
32.000	31.750(1 ¹ / ₄)	30.5	30.7	39.6	0.6	46 600	83 900	2 500	LRBZ 162020
32.000	34.925(1 ³ / ₈)	33.5	33.9	42.8	0.6	49 500	91 800	2 500	LRBZ 182220
32.000	38.100(1 ¹ / ₂)	37	37.1	47.3	0.6	54 200	97 700	2 000	LRBZ 202420
32.000	41.275(1 ⁵ / ₈)	40.2	40.2	50.5	0.6	56 600	105 000	1 900	LRBZ 222620
32.000	44.450(1 ³ / ₄)	43.3	43.4	53.7	0.6	58 900	114 000	1 800	LRBZ 242820
32.000	47.625(1 ⁷ / ₈)	43.3	45	56.2	1	61 100	121 000	1 700	LRBZ 243020
32.000	50.800(2)	48	49	59.2	1	63 100	130 000	1 600	LRBZ 263220
44.700	57.150(2 ¹ / ₄)	52.5	55	69.2	1.5	87 500	161 000	1 400	LRBZ 283628

MACHINED TYPE NEEDLE ROLLER BEARINGS

With Seal, With Inner Ring, Inch Series

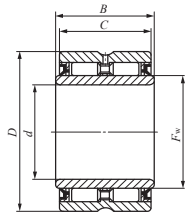

GBRI...UU

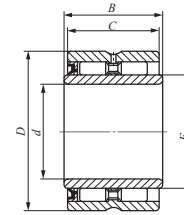

GBRI...U

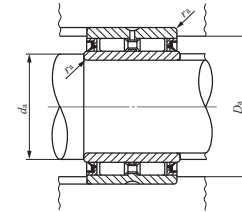

Shaft dia. 50.800 – 95.250mm

Shaft dia. mm (inch)	Identification number		Mass (Ref.) g	Boundary dimensions mm(inch)		
	With two seals	With one seal		<i>d</i>	<i>D</i>	<i>C</i>
50.800 (2)	GBRI 325228 UU	GBRI 325228 U	950	50.800 (2)	82.550 (3 1/4)	44.450 (1 3/4)
57.150 (2 1/4)	GBRI 365628 UU	GBRI 365628 U	1 050	57.150 (2 1/4)	88.900 (3 1/2)	44.450 (1 3/4)
63.500 (2 1/2)	GBRI 406028 UU	GBRI 406028 U	1 140	63.500 (2 1/2)	95.250 (3 3/4)	44.450 (1 3/4)
69.850 (2 3/4)	GBRI 446828 UU	GBRI 446828 U	1 490	69.850 (2 3/4)	107.950 (4 1/4)	44.450 (1 3/4)
76.200 (3)	GBRI 487232 UU	GBRI 487232 U	1 880	76.200 (3)	114.300 (4 1/2)	50.800 (2)
82.550 (3 1/4)	GBRI 527632 UU	GBRI 527632 U	2 010	82.550 (3 1/4)	120.650 (4 3/4)	50.800 (2)
88.900 (3 1/2)	GBRI 568032 UU	GBRI 568032 U	2 130	88.900 (3 1/2)	127.000 (5)	50.800 (2)
95.250 (3 3/4)	GBRI 608432 UU	GBRI 608432 U	2 260	95.250 (3 3/4)	133.350 (5 1/4)	50.800 (2)

Notes⁽¹⁾ Maximum permissible corner radius of the shaft or housing
⁽²⁾ Allowable rotational speed applies to grease lubrication.

Remarks1. The outer ring has an oil groove and an oil hole.
 2. Bearings with seals on both sides are provided with prepacked grease. Bearings with a seal on one side are not provided with prepacked grease. Perform proper lubrication for use.

<i>B</i>	<i>F_w</i>	Standard mounting dimensions mm				Basic dynamic load rating <i>C</i> N	Basic static load rating <i>C₀</i> N	Allowable rotational speed ⁽²⁾ rpm	Assembled inner ring
		<i>d_a</i> Min.	<i>d_a</i> Max.	<i>D_a</i> Max.	<i>r_{as max}</i> ⁽¹⁾				
44.700	63.500 (2 1/2)	58	61	75.7	1.5	93 300	179 000	1 300	LRBZ 324028
44.700	69.850 (2 3/4)	65	67	82	1.5	97 200	197 000	1 100	LRBZ 364428
44.700	76.200 (3)	71	73	88	1.5	101 000	215 000	1 100	LRBZ 404828
44.700	82.550 (3 1/4)	77	79	99.9	1.5	127 000	231 000	950	LRBZ 445228
51.050	88.900 (3 1/2)	83.5	86	106.3	1.5	170 000	347 000	900	LRBZ 485632
51.050	95.250 (3 3/4)	91	93	112.6	1.5	175 000	371 000	850	LRBZ 526032
51.050	101.600 (4)	97	99	119	1.5	182 000	395 000	800	LRBZ 566432
51.050	107.950 (4 1/4)	103	105	125.3	1.5	186 000	419 000	750	LRBZ 606832

D

NA
TAFI
TRI
BRI

C-LUBE MACHINED TYPE NEEDLE ROLLER BEARINGS

Structure and features

C-Lube Machined Type Needle Roller Bearing is a bearing that is lubricated with a newly developed thermosetting solid-type lubricant. A large amount of lubricating oil and fine particles of ultra high molecular weight polyolefin resin are solidified by heat treatment to fill the inner space of the bearing. As the bearing rotates, the lubricating oil oozes out onto the raceway in proper quantities, maintaining the lubrication performance for a long period of time. C-Lube Machined Type Needle Roller Bearings are bearings with a low sectional height and large load ratings. The outer ring has high rigidity and can easily be used even for light alloy housings.

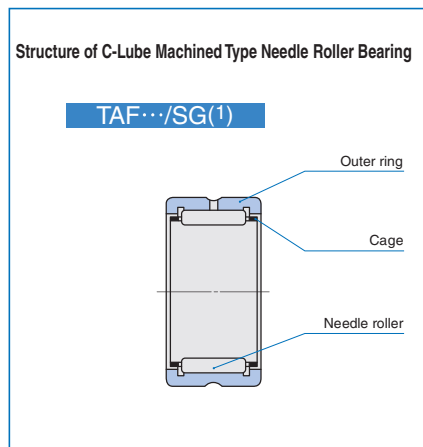

Note⁽¹⁾ Thermosetting solid-type lubricant fills inner space of the bearing.

Type

C-Lube Machined Type Needle Roller Bearing is available in type shown in Table 1.

Table 1 Type of bearing

Series	Type	Needle bearing with cage
		Without inner ring
Metric series	For light duty	TAF.../SG

Identification number

The identification number of C-Lube Machined Type Needle Roller Bearing consists of model code, dimensions and classification symbol. Example is shown below.

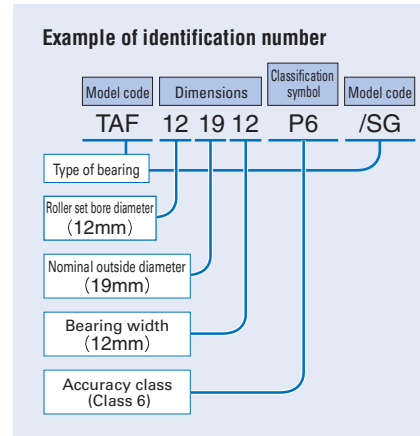

Accuracy

C-Lube Machined Type Needle Roller Bearings are manufactured based on JIS (See page A31.). The tolerances for the smallest single roller set bore diameter of bearings without inner ring are based on Table 14 on page A33.

Fit

The recommended fits for C-Lube Machined Type Needle Roller Bearings are shown in Tables 21 to 23 on pages A41 and A42.

Allowable Rotational Speed

The allowable rotational speed of C-Lube Machined Type Needle Roller Bearing is affected by mounting and operating conditions. The reference $d_{m,n}$ value (1) is 20,000.

Note⁽¹⁾ $d_{m,n}$ value = $\{(\text{Bore diameter of bearing [mm]} + \text{Outside diameter of bearing [mm]})/2\} \times \text{rotational speed [rpm]}$

Lubrication

As the internal space of C-Lube Machined Type Needle Roller Bearing is filled with thermosetting solid-type lubricant C-Lube, regreasing is not possible due to the structure.

Oil hole

Table 2 shows the number of oil holes on the outer ring.

Table 2 Number of oil holes of outer ring

Nominal roller set bore diameter F_w mm	Number of hole holes of outer ring
$F_w \leq 26$	0
$26 < F_w$	1

Remark If there is oil hole on the outer ring, care must be exercised not to let oil holes within the load range.

Mounting

- 1 Mounting dimensions for C-Lube Machined Type Needle Roller Bearings are shown in the table of dimensions.
- 2 When mounting, pay special attention to avoid locating the oil hole within the loading zone. This may lead to a short bearing life.

Precaution for Use

- 1 Do not wash C-Lube Machined Type Needle Roller Bearing with organic solvent and/or white kerosene, which have the ability of removing fat nor leave them in contact with the above agents.
- 2 To ensure normal rotation of the C-Lube Machined Type Needle Roller Bearing, apply a load of 1% or over of the dynamic load rating at use.
- 3 The operating temperature range is $-15 \sim +80^\circ\text{C}$. For continuous operation, the recommended operating temperature is $+60^\circ\text{C}$ or less.
- 4 When using two or more C-Lube Machined Type Needle Roller Bearings adjacent to each other on the same shaft, it is necessary to obtain an even load distribution. On request, a set of bearings is available, in which bearings are matched to obtain an even load distribution.

Further, C-Lube Machined Type Needle Roller Bearing for food machinery is also available. If needed, please contact **IKO**.

C-LUBE MACHINED TYPE NEEDLE ROLLER BEARINGS

Without Inner Ring

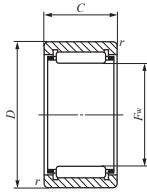

TAF.../SG
F_w ≤ 26

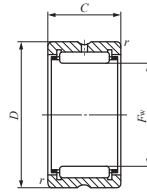

TAF.../SG
F_w > 26

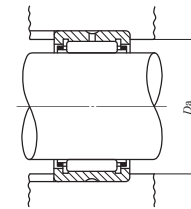

Shaft dia. 10–45mm

Shaft dia.	Identification number	Mass (Ref.) g	Boundary dimensions mm				Standard mounting dimension D _a Max. mm	Basic dynamic load rating C N	Basic static load rating C ₀ N
			F _w	D	C	r _s min ⁽¹⁾			
10	TAF 101712/SG	11	10	17	12	0.2	15.4	5 880	5 970
	TAF 101716/SG	14.7	10	17	16	0.2	15.4	8 230	9 190
12	TAF 121912/SG	12.5	12	19	12	0.3	17	6 610	7 260
	TAF 121916/SG	16.8	12	19	16	0.3	17	9 250	11 200
14	TAF 142216/SG	22	14	22	16	0.3	20	11 700	13 700
	TAF 142220/SG	27.5	14	22	20	0.3	20	14 800	18 600
15	TAF 152316/SG	23.5	15	23	16	0.3	21	12 300	14 900
	TAF 152320/SG	29	15	23	20	0.3	21	15 600	20 200
16	TAF 162416/SG	24	16	24	16	0.3	22	12 300	15 100
	TAF 162420/SG	30	16	24	20	0.3	22	15 500	20 400
18	TAF 182616/SG	26.5	18	26	16	0.3	24	13 400	17 500
	TAF 182620/SG	33	18	26	20	0.3	24	17 000	23 600
19	TAF 192716/SG	28	19	27	16	0.3	25	14 000	18 700
	TAF 192720/SG	35.5	19	27	20	0.3	25	17 700	25 300
20	TAF 202816/SG	28.5	20	28	16	0.3	26	13 900	18 800
	TAF 202820/SG	37	20	28	20	0.3	26	17 600	25 400
21	TAF 212916/SG	30	21	29	16	0.3	27	14 400	20 000
	TAF 212920/SG	37.5	21	29	20	0.3	27	18 200	27 100
22	TAF 223016/SG	31	22	30	16	0.3	28	14 900	21 200
	TAF 223020/SG	39	22	30	20	0.3	28	18 900	28 700
24	TAF 243216/SG	33	24	32	16	0.3	30	15 300	22 500
	TAF 243220/SG	42	24	32	20	0.3	30	19 400	30 500
25	TAF 253316/SG	35	25	33	16	0.3	31	15 800	23 700
	TAF 253320/SG	43.5	25	33	20	0.3	31	20 000	32 100

Note⁽¹⁾ Minimum allowable value of chamfer dimension r.

Remarks1. Models with a nominal roller set bore diameter F_w of 26mm or less are provided without oil holes. Other models are provided with one oil hole and oil groove.

2. This bearing can not be re-lubricated as thermosetting solid-type lubricant C-Lube fills inner space of the bearing.

Shaft dia.	Identification number	Mass (Ref.) g	Boundary dimensions mm				Standard mounting dimension D _a Max. mm	Basic dynamic load rating C N	Basic static load rating C ₀ N
			F _w	D	C	r _s min ⁽¹⁾			
29	TAF 293820/SG	59	29	38	20	0.3	36	21 600	37 200
	TAF 293830/SG	88	29	38	30	0.3	36	30 900	59 100
30	TAF 304020/SG	67	30	40	20	0.3	38	25 100	40 100
	TAF 304030/SG	101	30	40	30	0.3	38	36 000	63 900
35	TAF 354520/SG	76.5	35	45	20	0.3	43	26 900	46 200
	TAF 354530/SG	116.5	35	45	30	0.3	43	38 600	73 600
40	TAF 405020/SG	86	40	50	20	0.3	48	29 400	54 100
	TAF 405030/SG	130	40	50	30	0.3	48	42 300	86 200
45	TAF 455520/SG	95.5	45	55	20	0.3	53	31 000	60 200
	TAF 455530/SG	144	45	55	30	0.3	53	44 600	95 800

D

TAF.../SG

NEEDLE ROLLER BEARINGS WITH SEPARABLE CAGE

- Needle Roller Bearings with Separable Cage - Without Inner Ring
- Needle Roller Bearings with Separable Cage - With Inner Ring



Structure and Features

In **IKO** Needle Roller Bearings with Separable Cage, the inner ring, outer ring and **IKO** Needle Roller Cage are combined, and they can be separated easily. This type has a simple structure with high accuracy. In addition, the radial clearance can be freely chosen by selecting and combining these component parts. As Needle Roller Cages are used, these bearings have excellent rotational performance. These bearings are most suitable for mass-production high accuracy products such as machine tools, textile machinery, and printing machines.

Structures of Needle Roller Bearings with Separable Cage

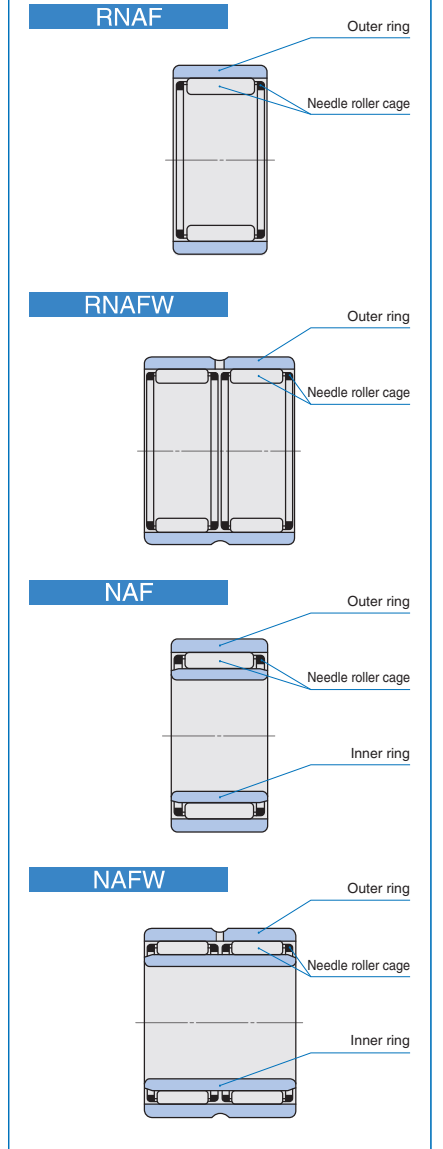

D
NAF

Types

Needle Roller Bearings with Separable Cage are available in the types shown in Table 1.

Table 1 Type of bearing

Type	Single-row		Double-row	
	Without inner ring	With inner ring	Without inner ring	With inner ring
Model code	RNAF	NAF	RNAFW	NAFW

Needle Roller Bearings with Separable Cage - Without Inner Ring

The single-row as well as the double-row types are available with the same sectional height, and either of them can be selected according to load conditions. As shown in the section, "Design of shaft and housing" on page A44, any desired radial internal clearance can be selected by combining a shaft which is heat-treated and finished by grinding.

Needle Roller Bearings with Separable Cage - With Inner Ring

These bearings are made to the CN clearance shown in Table 19 on page A37. When especially high accuracy is required, it is possible to supply semi-finished inner rings which have a finishing allowance on their outside diameter so that they can be ground after being press-fitted to shafts.

Identification Number

The identification number of Needle Roller Bearings with Separable Cage consists of a model code, dimensions, any supplemental codes and a classification symbol. The arrangement examples are as follows.

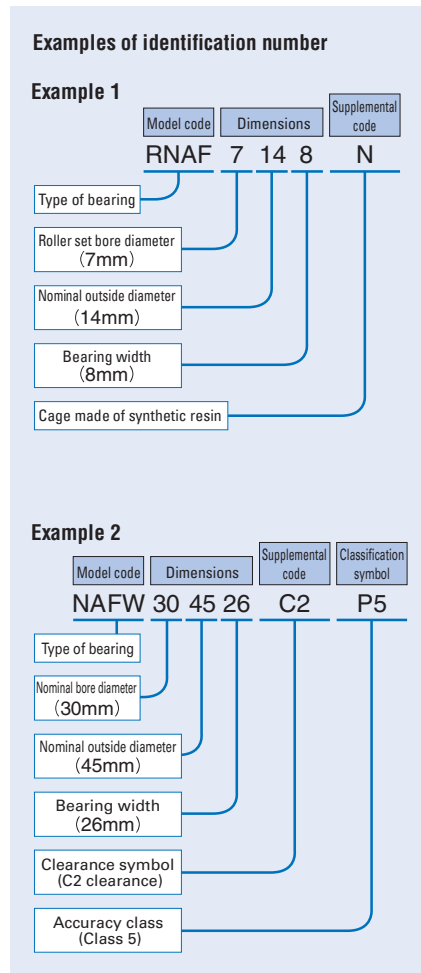

Accuracy

Needle Roller Bearings with Separable Cage are manufactured to the accuracy based on JIS (See page A31.). Tolerances for the smallest single roller set bore diameter of bearings without inner ring are based on Table 14 on page A33.

Clearance

Radial internal clearances of Needle Roller Bearings with Separable Cage are made to the CN clearance shown in Table 18 on page A37.

Fit

Recommended fits for Needle Roller Bearings with Separable Cage are shown in Tables 21 to 23 on pages A41 and A42.

Lubrication

Needle Roller Bearings with Separable Cage are not provided with prepacked grease. Perform proper lubrication for use. Using them without lubrication will increase the wear of the rolling contact surfaces and shorten their lives.

Oil Hole

The double-row type outer rings have both an oil hole and an oil groove, but the single-row type outer rings do not. When outer rings with an oil hole are required, attach "-OH" before the clearance symbol in the identification number, and when outer rings with both an oil hole and an oil groove are required, attach "-OG" to the same position.
Example: NAF 203517 - OH C2 P6

When outer rings with multiple oil holes or inner rings with oil hole(s) are required, please contact **IKO**.

Operating temperature range

For synthetic resin cages, "N" is added at the end of the identification number. The operating temperature range for Needle Roller Bearings with Separable Cage is -20 ~ +120°C. However, the maximum allowable temperature for synthetic resin cages is +110°C, and when they are continuously operated, it is +100°C.

Mounting

Mounting examples of Needle Roller Bearings with Separable Cage are shown in Fig.1.

When mounting Needle Roller Bearings with Separable Cage, it is necessary to locate the needle cage axially. The needle cage is guided by shoulders of the shaft and housing or by side plates, and their guide surfaces must be heat-treated and finished by grinding at right angles to the shaft central axis. Dimensions related to mounting are shown in the table of dimensions.

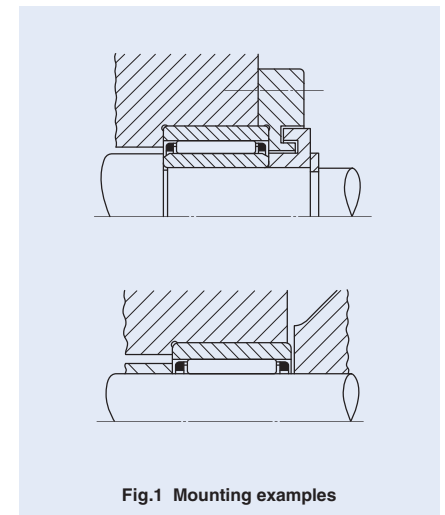
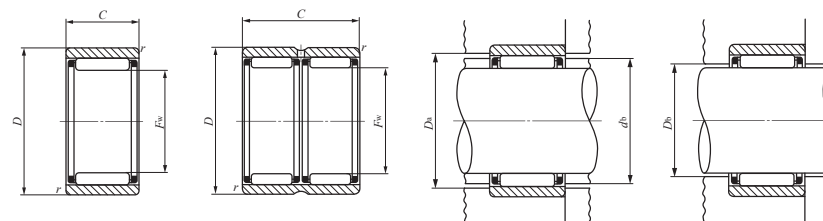

Fig.1 Mounting examples

NEEDLE ROLLER BEARINGS WITH SEPARABLE CAGE

Without Inner Ring



RNAF

RNAFW

Shaft dia. 5 – 18mm

Shaft dia. mm	Identification number	Mass (Ref.) g	Boundary dimensions mm				Standard mounting dimensions mm			Basic dynamic load rating C N	Basic static load rating C ₀ N
			F _w	D	C	r _{s min} ⁽¹⁾	d _b	D _a Max.	D _b		
5	RNAF 5108N	2.8	5	10	8	0.2	6.7	8.4	5.4	2 420	1 950
6	RNAF 6138N	5.5	6	13	8	0.3	8.4	11	6.4	2 700	2 320
7	RNAF 7148N	6.1	7	14	8	0.3	9.4	12	7.4	2 960	2 690
8	RNAF 81510	8.2	8	15	10	0.3	10.4	13	8.4	3 630	3 600
	RNAFW 81620	20.5	8	16	20	0.3	10.8	14	8.4	6 220	7 200
10	RNAF 101710	9.6	10	17	10	0.3	12.4	15	10.4	4 160	4 550
	RNAF 102012	18.7	10	20	12	0.3	13.5	18	10.4	5 940	6 000
12	RNAF 122212	19.5	12	22	12	0.3	15.5	20	12.4	9 030	8 460
14	RNAF 142213	18.7	14	22	13	0.3	17.6	20	14.6	7 860	9 410
	RNAFW 142220	28.5	14	22	20	0.3	17.6	20	14.6	10 800	14 200
	RNAF 142612	29	14	26	12	0.3	19.4	24	14.6	9 790	9 680
15	RNAF 152313	19.7	15	23	13	0.3	18.6	21	15.6	8 250	10 200
	RNAFW 152320	30.5	15	23	20	0.3	18.6	21	15.6	11 400	15 400
16	RNAF 162413	21	16	24	13	0.3	19.6	22	16.6	8 620	11 000
	RNAFW 162420	32	16	24	20	0.3	19.6	22	16.6	11 900	16 700
	RNAF 162812	31.5	16	28	12	0.3	21.4	26	16.6	10 500	10 900
17	RNAF 172513	22	17	25	13	0.3	20.6	23	17.6	8 980	11 800
	RNAFW 172520	33.5	17	25	20	0.3	20.6	23	17.6	12 400	17 900
18	RNAF 182613	23	18	26	13	0.3	21.6	24	18.6	9 330	12 700
	RNAFW 182620	35	18	26	20	0.3	21.6	24	18.6	12 900	19 100
	RNAF 183012	34.5	18	30	12	0.3	23.4	28	18.6	11 800	13 100
	RNAFW 183024	69.5	18	30	24	0.3	23.4	28	18.6	20 200	26 200

Notes⁽¹⁾ Minimum allowable value of chamfer dimension r
⁽²⁾ Allowable rotational speed applies to oil lubrication. For grease lubrication, a maximum of 50% of this value is allowable.
 Remarks1. The character "N" at the end of the identification number indicates that a synthetic resin cage is incorporated.
 2. RNAF has no oil hole. RNAFW is provided with an oil groove and an oil hole on the outer ring.
 3. No grease is prepacked. Perform proper lubrication.

Allowable rotational speed ⁽²⁾ rpm
85 000
75 000
65 000
60 000
60 000
50 000
50 000
40 000
35 000
35 000
35 000
35 000
35 000
35 000
30 000
30 000
30 000
30 000
30 000
30 000
30 000
30 000
30 000



NEEDLE ROLLER BEARINGS WITH SEPARABLE CAGE

Without Inner Ring

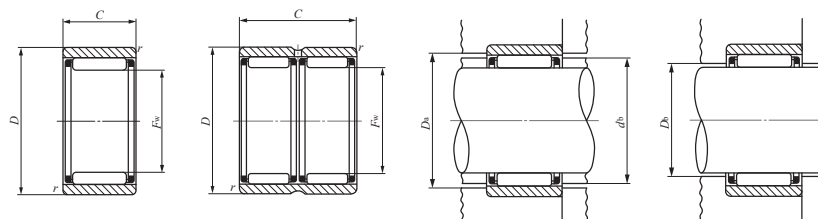
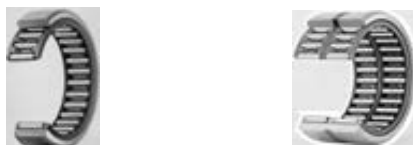

RNAF

RNAFW

Shaft dia. 45 – 100mm

Shaft dia. mm	Identification number	Mass (Ref.) g	Boundary dimensions mm				Standard mounting dimensions mm			Basic dynamic load rating C N	Basic static load rating C ₀ N
			F _w	D	C	r _{s min} ⁽¹⁾	d _b	D _a Max.	D _b		
45	RNAF 455517	83.5	45	55	17	0.3	48.5	53	45.8	23 300	47 100
	RNAFW 455534	167	45	55	34	0.3	48.5	53	45.8	39 900	94 200
	RNAF 456220	184	45	62	20	0.3	50.9	60	45.8	33 200	53 300
	RNAFW 456240	370	45	62	40	0.3	50.9	60	45.8	56 900	107 000
50	RNAF 506220	138	50	62	20	0.3	54.2	60	50.8	27 100	59 300
	RNAFW 506240	275	50	62	40	0.3	54.2	60	50.8	46 400	119 000
	RNAF 506520	170	50	65	20	0.3	55.2	63	50.8	35 900	61 100
	RNAFW 506540	340	50	65	40	0.6	55.2	61	50.8	61 500	122 000
55	RNAF 556820	167	55	68	20	0.3	59.5	66	55.8	28 600	66 000
	RNAFW 556840	335	55	68	40	0.3	59.5	66	55.8	49 000	132 000
	RNAF 557220	220	55	72	20	1	60.9	67	55.8	37 400	66 400
	RNAFW 557240	440	55	72	40	1	60.9	67	55.8	64 100	133 000
60	RNAF 607820	255	60	78	20	1	66.3	73	60.8	38 900	71 700
	RNAFW 607840	510	60	78	40	1	66.3	73	60.8	66 700	143 000
65	RNAF 658530	470	65	85	30	1.5	72	77	66	59 300	127 000
	RNAFW 658560	945	65	85	60	1.5	72	77	66	102 000	255 000
70	RNAF 709030	500	70	90	30	1.5	77	82	71	61 200	136 000
	RNAFW 709060	1 000	70	90	60	1.5	77	82	71	105 000	272 000
75	RNAF 759530	530	75	95	30	1.5	82	87	76	63 100	144 000
	RNAFW 759560	1 060	75	95	60	1.5	82	87	76	108 000	289 000
80	RNAF 8010030	560	80	100	30	1.5	87	92	81	65 000	153 000
	RNAFW 8010060	1 120	80	100	60	1.5	87	92	81	111 000	306 000
85	RNAF 8510530	590	85	105	30	1.5	92	97	86	66 600	161 000
90	RNAF 9011030	625	90	110	30	1.5	97	102	91	69 600	174 000
95	RNAF 9511530	655	95	115	30	1.5	102	107	96	70 900	182 000
100	RNAF 10012030	685	100	120	30	1.5	107	112	101	72 500	191 000

Notes⁽¹⁾ Minimum allowable value of chamfer dimension r

⁽²⁾ Allowable rotational speed applies to oil lubrication. For grease lubrication, a maximum of 50% of this value is allowable.

Remarks1. RNAF has no oil hole. RNAFW is provided with an oil groove and an oil hole on the outer ring.

2. No grease is prepacked. Perform proper lubrication.

Allowable rotational speed ⁽²⁾ rpm
11 000
11 000
11 000
11 000
10 000
10 000
10 000
10 000
9 000
9 000
9 000
9 000
8 500
8 500
7 500
7 500
7 000
7 000
6 500
6 500
6 000
6 000
6 000
5 500
5 500
4 500



NEEDLE ROLLER BEARINGS WITH SEPARABLE CAGE

With Inner Ring



Shaft dia. 6 – 25mm

Shaft dia. mm	Identification number	Mass (Ref.) g	Boundary dimensions mm					Standard mounting dimensions mm					
			<i>d</i>	<i>D</i>	<i>C</i>	<i>r</i> _{s min} ⁽¹⁾	<i>F</i> _w	<i>d</i> _b	<i>D</i> _a Max.	<i>d</i> _a Min. Max.		<i>D</i> _b	
6	NAF 61710	13.5	6	17	10	0.3	10	12.4	15	8	9.7	10.4	
	7	NAF 72012	22.5	7	20	12	0.3	10	13.5	18	9	9.7	10.4
	9	NAF 92212	24	9	22	12	0.3	12	15.5	20	11	11.5	12.4
10	NAF 102213	26	10	22	13	0.3	14	17.6	20	12	13	14.6	
	NAFW 102220	40	10	22	20	0.3	14	17.6	20	12	13	14.6	
	NAF 102612	36	10	26	12	0.3	14	19.4	24	12	13	14.6	
12	NAF 122413	29.5	12	24	13	0.3	16	19.6	22	14	15	16.6	
	NAFW 122420	45.5	12	24	20	0.3	16	19.6	22	14	15	16.6	
	NAF 122812	40	12	28	12	0.3	16	21.4	26	14	15	16.6	
15	NAF 152813	38.5	15	28	13	0.3	20	23.6	26	17	19	20.6	
	NAFW 152826	77.5	15	28	26	0.3	20	23.6	26	17	19	20.6	
	NAF 153212	50.5	15	32	12	0.3	20	25.4	30	17	19	20.6	
17	NAF 173013	42.5	17	30	13	0.3	22	25.6	28	19	21	22.6	
	NAFW 173026	84.5	17	30	26	0.3	22	25.6	28	19	21	22.6	
	NAF 173516	77.5	17	35	16	0.3	22	27.8	33	19	21	22.6	
20	NAFW 173532	155	17	35	32	0.3	22	27.8	33	19	21	22.6	
	NAF 203517	74	20	35	17	0.3	25	29.5	33	22	24	25.6	
	NAFW 203526	114	20	35	26	0.3	25	29.5	33	22	24	25.6	
25	NAF 203716	79	20	37	16	0.3	25	30.4	35	22	24	25.6	
	NAFW 203732	158	20	37	32	0.3	25	30.4	35	22	24	25.6	
	NAF 254017	87.5	25	40	17	0.3	30	34.5	38	27	29	30.6	
25	NAFW 254026	135	25	40	26	0.3	30	34.5	38	27	29	30.6	
	NAF 254216	94	25	42	16	0.3	30	35.4	40	27	29	30.6	
	NAFW 254232	186	25	42	32	0.3	30	35.4	40	27	29	30.6	

Notes⁽¹⁾ Minimum allowable value of chamfer dimension *r*
⁽²⁾ Allowable rotational speed applies to oil lubrication. For grease lubrication, a maximum of 50% of this value is allowable.
 Remarks1. NAF has no oil hole. NAFW is provided with an oil groove and an oil hole on the outer ring.
 2. No grease is prepacked. Perform proper lubrication.

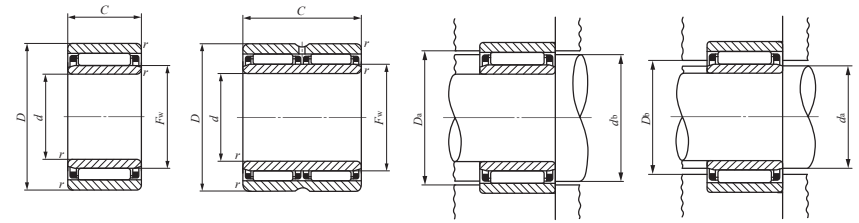

NAF

NAFW

Basic dynamic load rating <i>C</i> N	Basic static load rating <i>C</i> ₀ N	Allowable rotational speed ⁽²⁾ rpm	Assembled inner ring
4 160	4 550	50 000	LRT 61010
5 940	6 000	50 000	LRT 71012-1
9 030	8 460	40 000	LRT 91212
7 860	9 410	35 000	LRT 101413
10 800	14 200	35 000	LRT 101420
9 790	9 680	35 000	LRT 101412
8 620	11 000	30 000	LRT 121613
11 900	16 700	30 000	LRT 121620
10 500	10 900	30 000	LRT 121612
9 590	13 500	25 000	LRT 152013
16 400	27 100	25 000	LRT 152026
12 400	14 300	25 000	LRT 152012
10 200	15 200	25 000	LRT 172213
17 500	30 300	25 000	LRT 172226
17 600	20 900	25 000	LRT 172216
30 200	41 800	25 000	LRT 172232
17 300	26 600	20 000	LRT 202517
22 400	37 200	20 000	LRT 202526
19 400	24 500	20 000	LRT 202516
33 200	49 000	20 000	LRT 202532
18 700	31 100	17 000	LRT 253017
24 200	43 400	17 000	LRT 253026
20 800	28 400	17 000	LRT 253016
35 700	56 800	17 000	LRT 253032

D

NAF

NEEDLE ROLLER BEARINGS WITH SEPARABLE CAGE

With Inner Ring

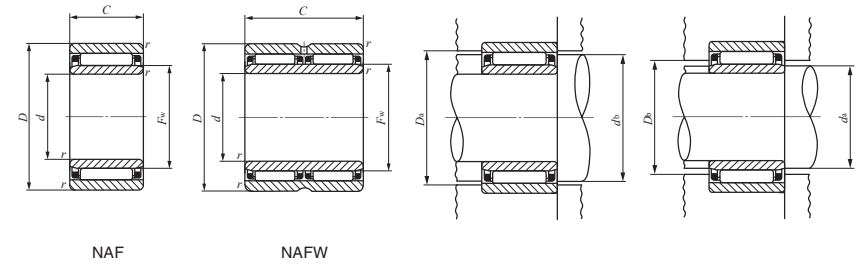

Shaft dia. 30 – 65mm

Shaft dia. mm	Identification number	Mass (Ref.) g	Boundary dimensions mm					Standard mounting dimensions mm				
			d	D	C	r _{s min} ⁽¹⁾	F _w	d _b	D _a Max.	d _a Min. Max.	D _b	
30	NAF 304517	101	30	45	17	0.3	35	39.5	43	32	34	35.6
	NAFW 304526	155	30	45	26	0.3	35	39.5	43	32	34	35.6
	NAF 304716	107	30	47	16	0.3	35	40.4	45	32	34	35.6
	NAFW 304732	215	30	47	32	0.3	35	40.4	45	32	34	35.6
35	NAF 355017	115	35	50	17	0.3	40	43.5	48	37	39	40.8
	NAFW 355034	230	35	50	34	0.3	40	43.5	48	37	39	40.8
	NAF 355520	186	35	55	20	0.3	40	45.2	53	37	39	40.8
	NAFW 355540	375	35	55	40	0.3	40	45.2	53	37	39	40.8
40	NAF 405517	128	40	55	17	0.3	45	48.5	53	42	44	45.8
	NAFW 405534	255	40	55	34	0.3	45	48.5	53	42	44	45.8
	NAF 406220	235	40	62	20	0.3	45	50.9	60	42	44	45.8
	NAFW 406240	475	40	62	40	0.3	45	50.9	60	42	44	45.8
45	NAF 456220	196	45	62	20	0.3	50	54.2	60	47	49	50.8
	NAFW 456240	390	45	62	40	0.3	50	54.2	60	47	49	50.8
	NAF 457220	340	45	72	20	1	55	60.9	67	50	54	55.8
	NAFW 457240	685	45	72	40	1	55	60.9	67	50	54	55.8
50	NAF 506820	230	50	68	20	0.3	55	59.5	66	52	54	55.8
	NAFW 506840	465	50	68	40	0.3	55	59.5	66	52	54	55.8
	NAF 507820	390	50	78	20	1	60	66.3	73	55	59	60.8
	NAFW 507840	775	50	78	40	1	60	66.3	73	55	59	60.8
55	NAF 558530	690	55	85	30	1.5	65	72	77	63	63.5	66
	NAFW 558560	1 380	55	85	60	1.5	65	72	77	63	63.5	66
60	NAF 609030	740	60	90	30	1.5	70	77	82	68	68.5	71
	NAFW 609060	1 480	60	90	60	1.5	70	77	82	68	68.5	71
65	NAF 659530	790	65	95	30	1.5	75	82	87	73	73.5	76
	NAFW 659560	1 580	65	95	60	1.5	75	82	87	73	73.5	76

Notes⁽¹⁾ Minimum allowable value of chamfer dimension r
⁽²⁾ Allowable rotational speed applies to oil lubrication. For grease lubrication, a maximum of 50% of this value is allowable.
 Remarks1. NAF has no oil hole. NAFW is provided with an oil groove and an oil hole on the outer ring.
 2. No grease is prepacked. Perform proper lubrication.

Basic dynamic load rating C	Basic static load rating C ₀	Allowable rotational speed ⁽²⁾	Assembled inner ring
N	N	rpm	
20 500	36 900	14 000	LRT 303517
26 600	51 500	14 000	LRT 303526
23 100	33 900	14 000	LRT 303516
39 500	67 800	14 000	LRT 303532
22 200	42 700	12 000	LRT 354017
38 000	85 400	12 000	LRT 354034
31 400	48 000	12 000	LRT 354020
53 900	96 000	12 000	LRT 354040
23 300	47 100	11 000	LRT 404517
39 900	94 200	11 000	LRT 404534
33 200	53 300	11 000	LRT 404520
56 900	107 000	11 000	LRT 404540
27 100	59 300	10 000	LRT 455020
46 400	119 000	10 000	LRT 455040
37 400	66 400	9 000	LRT 455520
64 100	133 000	9 000	LRT 455540
28 600	66 000	9 000	LRT 505520
49 000	132 000	9 000	LRT 505540
38 900	71 700	8 500	LRT 506020
66 700	143 000	8 500	LRT 506040
59 300	127 000	7 500	LRT 556530
102 000	255 000	7 500	LRT 556560
61 200	136 000	7 000	LRT 607030
105 000	272 000	7 000	LRT 607060
63 100	144 000	6 500	LRT 657530
108 000	289 000	6 500	LRT 657560



NEEDLE ROLLER BEARINGS WITH SEPARABLE CAGE

With Inner Ring

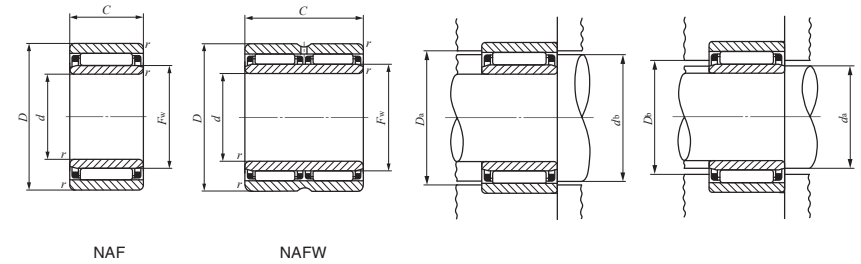

Shaft dia. 70 – 90mm

Shaft dia. mm	Identification number	Mass (Ref.) g	Boundary dimensions mm					Standard mounting dimensions mm				
			d	D	C	r _{s min} ⁽¹⁾	F _w	d _b	D _a Max.	Min.	d _a Max.	D _b
70	NAF 7010030	835	70	100	30	1.5	80	87	92	78	78.5	81
	NAFW 7010060	1 680	70	100	60	1.5	80	87	92	78	78.5	81
75	NAF 7510530	885	75	105	30	1.5	85	92	97	83	83.5	86
80	NAF 8011030	935	80	110	30	1.5	90	97	102	88	88.5	91
85	NAF 8511530	985	85	115	30	1.5	95	102	107	93	93.5	96
90	NAF 9012030	1 040	90	120	30	1.5	100	107	112	98	98.5	101

Notes⁽¹⁾ Minimum allowable value of chamfer dimension r
⁽²⁾ Allowable rotational speed applies to oil lubrication. For grease lubrication, a maximum of 50% of this value is allowable.
 Remarks1. NAF has no oil hole. NAFW is provided with an oil groove and an oil hole on the outer ring.
 2. No grease is prepacked. Perform proper lubrication.

Basic dynamic load rating C N	Basic static load rating C ₀ N	Allowable rotational speed ⁽²⁾ rpm	Assembled inner ring
65 000	153 000	6 000	LRT 708030-1
111 000	306 000	6 000	LRT 708060
66 600	161 000	6 000	LRT 758530-1
69 600	174 000	5 500	LRT 809030-1
70 900	182 000	5 500	LRT 859530
72 500	191 000	4 500	LRT 9010030

D
NAF