

Bearing Unit

LSGR 205 FS

Bearing Unit
Packer Roller

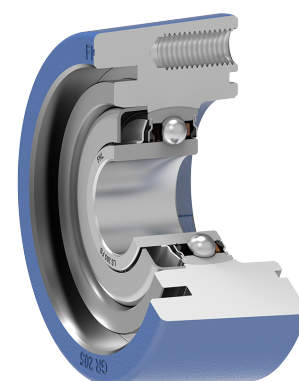
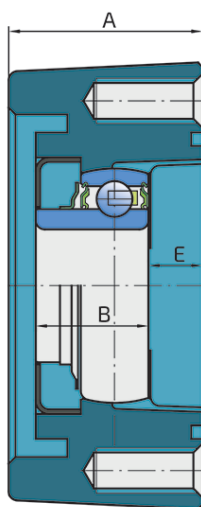
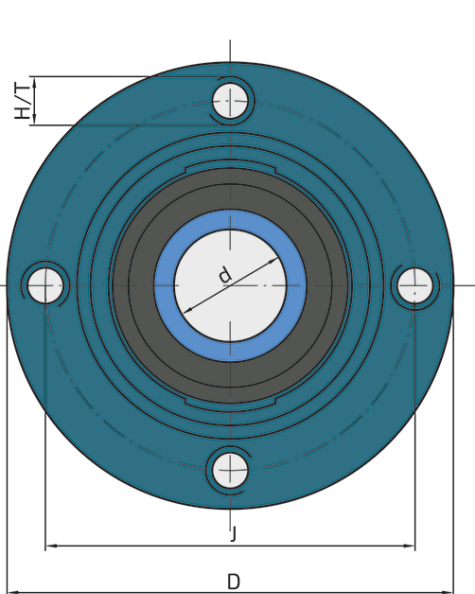
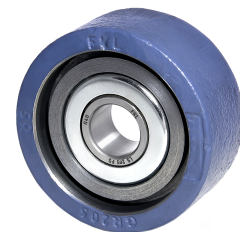

Technical Specification

d	Bore diameter	25 mm
D	Outside diameter	99 mm
J	Pitch circle diameter	82 mm
H/T	Hole/Thread	M10 mm
A	Overall width	43 mm
B	Width inner ring	25 mm
E	Distance from housing flange to bearing face	12 mm
kg	Mass	1.55 kg
C _{dyn}	Dynamic load rating	14 kN
C _o	Static load rating	7.8 kN
P _u	Fatigue load limit	0.328 kN

Sealing

METAL COVER RING+METAL FLINGER RING+S SEAL / S SEAL

S seal on the base side and S seal with Metal flinger ring and Metal cover ring on the front side which is exposed to contaminants.

The Metal cover ring protects the seal from mechanical damage and from entanglement of grass stems of plants and twines.

